

Medical Additive Manufacturing: Challenges and Features

Avesahemad S. N. Husainy¹, Sagar D. Patil², Rushikesh S. Kokane³,
Chintamani R. Upadhye⁴ and Abhishek V. Chougule⁵

¹Assistant Professor, ²Associate Professor, ^{3,4&5}UG Research Scholar,
^{1,2,3,4&5}Department of Mechanical Engineering, Sharad Institute of Technology,
College of Engineering, Yadrav, Ichalkaranji, Maharashtra, India
E-mail: avesahemad@gmail.com

(Received 20 January 2023; Revised 13 February 2023, Accepted 10 March 2023; Available online 16 March 2023)

Abstract - Over the past 20 years, Medical Additive Manufacturing has been immensely developed and become an essential part of Contemporary healthcare. In the past, additive manufacturing was only utilized to develop basic anatomical models, but as technology evolved, it became more straightforward for researchers to produce complex medical devices. Medical additive manufacturing is a promptly emerging field with the competence to print living tissues and organs for transplantation and produce personalized implants and prostheses with astounding precision and accuracy. The ability of 3D printing to produce products that precisely match a patient's unique anatomy has significant benefits for medicine, including better patient outcomes. Additive manufacturing is often employed in the orthopedic and dentistry fields to design, build, or produce parts specifically for the patient's exact and ideal fit. Additionally, it is extensively being utilized to produce surgical equipment and customized anatomical models for pre-surgical planning. This allows surgeons to practice complex procedures on a replica of the patient's anatomy, improving surgical outcomes and reducing the risk of complications. Experts are exploring the possibility of utilizing 3D printing techniques for developing innovative methods to administer medication, which could improve treatment effectiveness and patient well-being. Additionally, these advancements have contributed immensely to creating human organs through bio-printing technology; a progress that has the potential to revolutionize organ transplants as they exist today by reducing dependence on donors. Another imminent advancement is surgical robotics using robots created through 3D printing procedures working side by side with medical experts thus improving patient outcomes and decreasing risks associated with traditional surgery techniques. Ongoing research and development promise even more groundbreaking applications in the future. This research article gives an attempt at medical additive manufacturing research now, then, and in the future.

Keywords: 3D Printing, Industry 4.0, Medical Research, Additive Manufacturing, Applications

I. INTRODUCTION

The term additive manufacturing is commonly associated with 3D printing, which has revolutionized the entire manufacturing industry by having a significant impact on producing complex, accurate, and precise parts. With conventional manufacturing methods, it would have been impossible to generate the technologically advanced and intricate shapes that can now be made through this modern

technology. The manufacturing industry is confronted with a spike in global competition, diversification of customer demands, and erratic and dynamic market trends to integrate design, manufacturing, and product support processes in order to accelerate product development and manage the steadily rising complexity of products and manufacturing enterprises without compromising quality. The conventional industry has also been significantly impacted by such technological advances [1].

The medical sector has recently embraced the usage of 3D printing. The production of medical equipment, prosthetics, diagnostic implants, and devices has already been made possible by the use of additive manufacturing in the healthcare sector. Regenerative medicine and tissue engineering have more recently incorporated Additive Manufacturing technology to help with tissue and organ regeneration [6]. Until the early 2000s, medical additive manufacturing was solely used to create anatomical models for educational purposes such as preoperative planning. Technology advancements and the diversity in printing materials have made it feasible to produce a broad variety of medical devices including surgical instruments, implants, and prosthetics. It became less challenging to reproduce the genuine part for the patient in order to provide a precise fit and lower the risk of complications.

Orthopedics, dentistry, and cardiology are just a few of the areas of medicine that employ medical additive manufacturing today. It was initially used extensively as a rapid prototyping and modeling technique in the 1980s, but it is now utilized to create a broad variety of shapes utilizing a number of different materials [2]. Although the first forms of 3D printing date back to topography and photo sculpture methods used more than 150 years ago, contemporary 3D printing, which is regarded as one of the most revolutionary technologies of the twenty-first century, was only created 40 years ago [3].

In any knowledge-based economy in the twenty-first century, additive manufacturing is thought to be essential for ensuring the competitiveness of a variety of industry sectors. It will also play a vital part in the R&D, innovation, and cluster strategies of many organizations [6]. By offering

an endless supply of replacement organs and tissues, bioprinting is anticipated to revolutionize regenerative medicine in the coming years. Additionally, it is anticipated that 3D printing in medicine will become more widely available and reasonably priced, enabling more people to get access to personalized medical treatments. The potential for additive manufacturing in the field of medicine are almost endless because of ongoing technological and material breakthroughs.

Selective Laser Sintering (SLS), Stereolithography (SLA), Fused Deposition Modeling (FDM), Multijet/Polyjet 3D Printing, Digital Light Processing (DLP), Direct Metal Laser Sintering (DMLS), Selective Deposition Lamination (SDL), Binding Jetting/Projet 3D Printing, Electron Beam Melting (EBM), and Laminated Object Manufacturing (LOM) are some of the printing technologies used in additive manufacturing (AM).

Modern additive manufacturing (3D printing) techniques have been developed and are providing a number of benefits over conventional production methods [4]. To create bones, implants, and other medical devices, rapid prototyping (RP) uses the knowledge of specialists from a variety of disciplines, including reverse engineering, medicine, biomaterials, design, and production. This technology is crucial for both diagnosis and therapy and it also significantly contributes to the fabrication of surgical instruments.

Rapid manufacturing makes it possible to, quickly and accurately produce patient-specific models and devices, which is one of the primary advantage in the medical industry [5]. The design alongside manufacturing of complex surgical medical implants, instruments, and devices are all accomplished through quickly developing medical technology additive manufacturing (AM). This technology is especially useful for developing biocompatible materials with high strength and elasticity, which creates new possibilities for making exact, custom-fit medical devices that may save patients' lives. AM has many benefits for the medical industry, including the ability to, rapidly and precisely produce patient-specific models and implants [4].

A new technology called 4D printing has recently sparked more attention because it advances 3D printing by allowing things to change over time in reaction to external factors. Using a broad spectrum of materials, 4D printing is an additive manufacturing process that produces complicated shapes with a range of properties in a single component. With the aid of this technology, implantable materials with specialized molecular compositions and adjustable surface characteristics can be created [2].

"4D printing is the evolution of a 3D printed structure's shape, properties, and functionality over time as it is exposed to heat, light, water, pH, and so on." This is the description that best illustrates the way 4D printing

contrasts with 3D printing. When compared to conventional methods, it also provides better efficiency, durability, and performance given that 4D-printed structures can self-improve their characteristics [9].

II. ADDITIVE MANUFACTURING

Additive manufacturing, also known as 3D printing, is a rapidly emerging technology that has revolutionized the manufacturing industry by enabling the creation of complex objects and parts with a high degree of accuracy and precision. Unlike traditional subtractive manufacturing processes, which involve removing material from a larger piece, Additive Manufacturing involves adding material layer by layer to build up the desired shape. In reality, AM technologies have evolved from the Rapid Prototyping (RP) method to a direct digital manufacturing approach that is used to produce finished things rather than merely prototypes [2].

Due to its widespread use in many industries today, additive manufacturing has a high potential. It is potentially made flexible with a variety of materials, including metal alloys, ceramics, thermoplastics, composites, and pure metals with thin walls [4]. Numerous industries, including automotive, aerospace, defense, medical, consumer goods, architecture, food, and others have found a use for the distinctive characteristics of AM technologies to create complex structures with multi-material features [1].

III. ADDITIVE MANUFACTURING IN MEDICAL INDUSTRY

In the 1980s, several companies were unable to use RP in prototype development due to the high cost of materials and equipment as well as its limited applications. The Wake Forest Institute for Regenerative Medicine in the United States employed additive manufacturing in the 1990s to create three-dimensional structures for replicating human organs [2]. By appropriately using this technology in the medical industry, it decreases the number of production processes for making medical parts, material waste during production, and inventory removes the amount of tooling necessary, and manufactures the full component in less time and at a lower cost [4]. Fig. 1 describes the steps involved in printing a part for utilization in medical additive manufacturing.

3D bio-printing, which emerged in 2003, is the primary method that is extensively utilized in medical additive manufacturing to print tissues and organs to construct various parts of the body. The fields of tissue engineering and regenerative medicine made significant strides during this time, and numerous research investigations on the development of tissues and organs have been carried out. In this procedure, tissues that resemble three-dimensional structures are created by feeding cells to a biocompatible scaffold using a 3D printer [3].

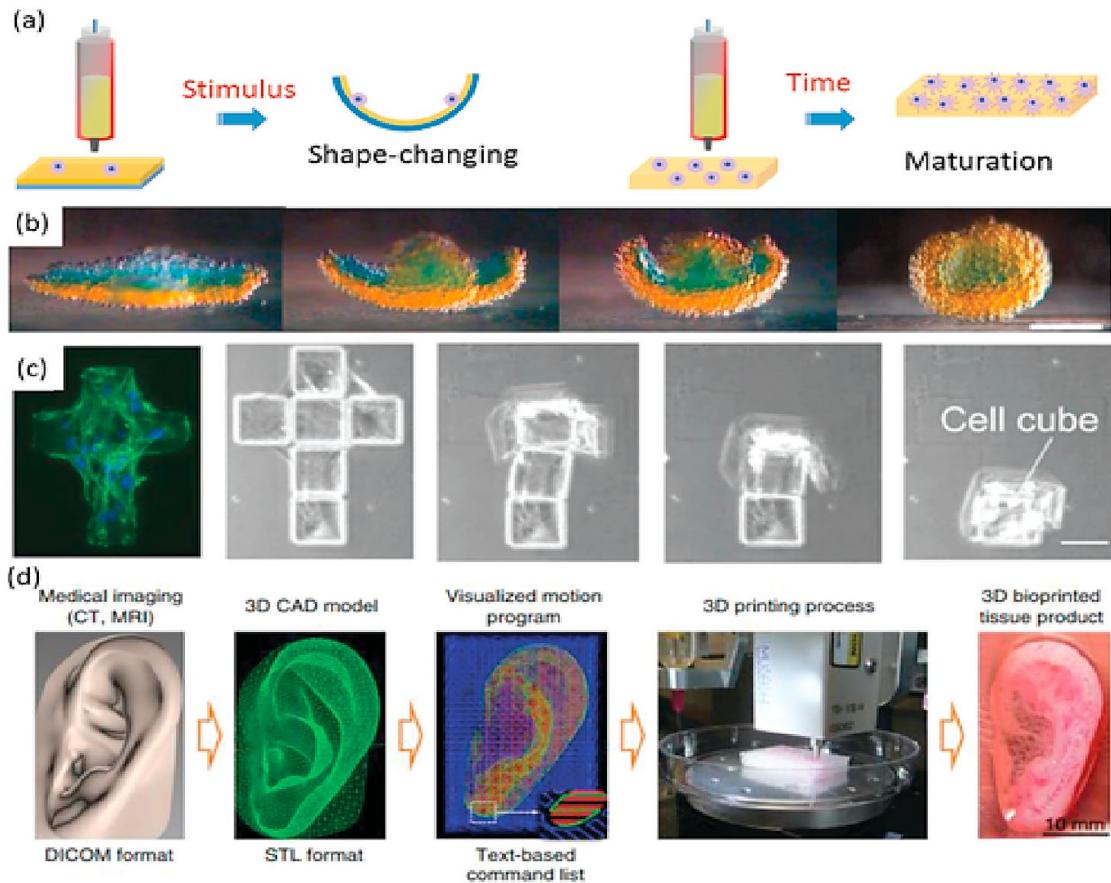

Fig 1. Diagrammatic representation of bio printing [9]

(a) Shape-changing and maturation of 4D printed biomaterial (b) and self-folding origami folded into a cube, and (c) ITOP-based printing of tissues and organs

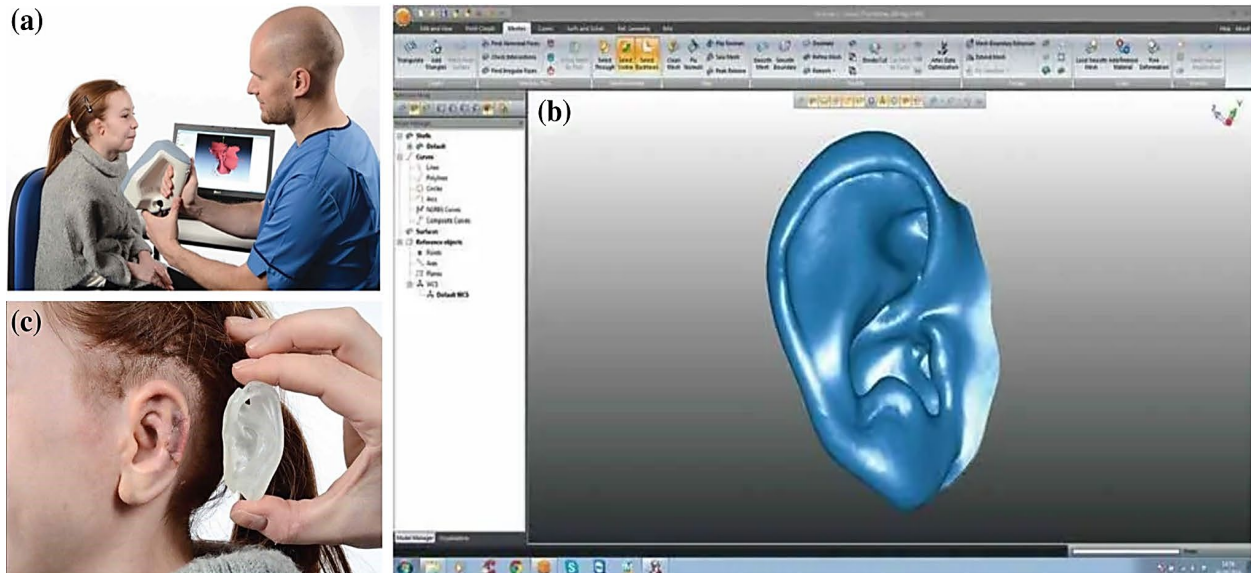

Fig. 2 (a) Scan of the 3d model; (b) exploration of the file sent to equipment; (c) part manufactured by additive manufacturing [2]

Biomaterials constitute a significant portion of the items used in healthcare. Biomedical devices (such as biosensors, blood circulation tubes, hemodialysis systems, and so on), implantable materials (such as sutures, plaques, bone substitutes, screens or meshes, heart valves, lenses, and

teeth), drug delivery devices (in the form of films, subdermal implants, and particles), and artificial organs (such as the heart, kidney, liver, pancreas, lungs, and skin) are examples of healthcare products made of biomaterials [2]. The majority of the production of implants has been

replaced with personalized pre-operative creation of implants based on a digitized 3D patient model by virtue of recent advances in AM technology [1]. Figure 1 shows some of the examples of medical models prosthetics that are made for education, training, or also actual operative models produced by using additive manufacturing as

follows: (a) a preoperative model of a skull and heart, (b) craniomaxillofacial implants, (c) a dental drilling guide, reduction forceps, nasal and throat swabs, (d) personalized and mobilizing external support and (e) a scaffold for zygomatic bone replacement and resorbable orbital implants [7].

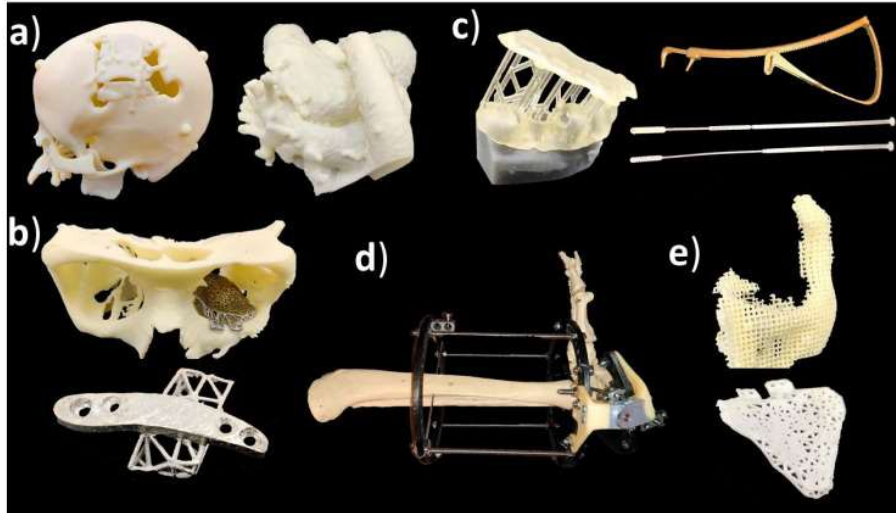

Fig. 3 (a) Medical models; (b) implants; (c) tools, instruments, and parts for medical devices; (d) medical aids, supportive guides, splints, and prostheses; (e) bio manufacturing [7]

IV. MATERIALS USED IN MEDICAL ADDITIVE MANUFACTURING

There are many more 3D printing materials that provide different kinds of applications by considering biocompatibility, sterilization, strength, durability, feasibility, comfortness. The tendency of a biomaterial to come into touch with human bodily tissues without endangering the body is the main characteristic that sets it apart from other materials. The majority of “materials for use in health” fall under the category of biomaterials and are employed in the production of items like prosthetics, lenses, grafts, stents, catheters, extracorporeal circulation tubes, tissue engineering frames, dental implants, orthopedic fasteners, etc. [2]. According to the application, the material is decided or accordingly the properties of the material is modified. Titanium and its alloys are the most commonly used biocompatible materials in the fabrication of implants and medical devices such as dental implants, orthopedic implants, cranial implants, and surgical instruments due to their high strength-to-weight ratio, mechanical strength, corrosion resistance, oxidation resistance, and low density [3]. 3D models in the medical industry are made from a broad range of materials according to their applications such materials are listed as follows: Plastic, Silicon, Acrylonitrile Butadiene Styrene (ABS), Polylactic Acid (PLA), Metal, Polyvinyl Alcohol Plastic (PVA), Tissue and Cell, Powder, Alumide, Carbon Fiber, Nitinol, Polyurethane Foam, Graphene, Titanium, Polyethylene, Polyether Ether Ketone (PEEK), etc [4]. An ideal scaffold material for bone prostheses has to be biodegradable, an osteoconductive is a kind of material that allows the growth of bones and fits

well with the body. It likewise ought to encourage capillary and cell growth for osteoconductive and capillary and cell growth for osteoinductivity, enabling regeneration in previously non-healing regions [8]. Emerging trends include the use of RP/RM and RE for dentistry applications, as well as the use of EBM instead of the prevalent SLM technique for direct metal production of biocompatible materials [4].

V. METHODS FOR ADDITIVE MANUFACTURING

According to the application of the model, a variety of techniques are used to create 3D models using additive manufacturing technology, implementing other factors like complexity, materials used, time, and primary structure and strength requirements into account. Since modern 3D printing has only been around for a little over 40 years, numerous methods have been invented for it, and some of the most widely used 3D printing technologies are outlined below.

A. Selective Laser Sintering (SLS)

Selective Laser Sintering (SLS) is a method that was developed by Carl Deckard at the University of Texas in 1981. It is a powder bed fusing procedure in which the component is constructed inside a sealed room that is filled with nitrogen gas, which aids in reducing oxidation and also reduces powder deterioration [3]. The process of selective laser sintering is very similar to that of SLA printing, but the material is in the form of powder (mostly polymer), which is first placed on a platform bed and then heated by a laser to melt the powder’s surface and cause diffusion. As

shown in the figure below, the print platform is then adjusted by lowering and a roller distributes a fresh powder coating over the old working surface [8]. SLS is frequently

employed in the medical industry to produce temporary and biodegradable rigid implants as well as metallic implants for the dentistry, craniofacial, and orthopedic fields [2].

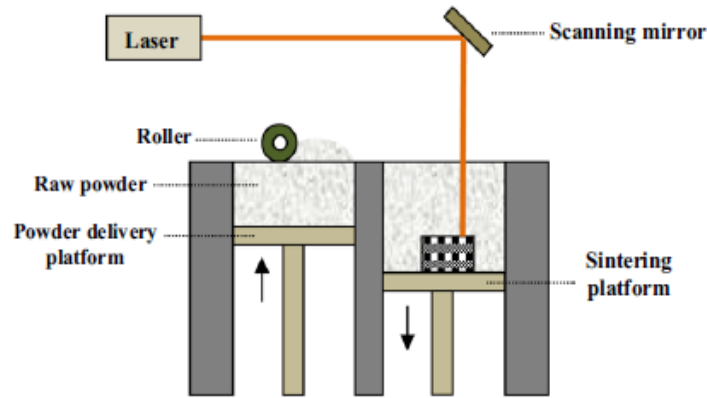

Fig. 4 Selective Laser Sintering (SLS) [8]

B. Stereolithography (SLA)

It is a 3D printing technique that relies on the photopolymerization principle, which was first patented by Charles Hull in 1984 [3]. When the photosensitive material is subjected to the laser, it solidifies on a platform bed, and a layer is created by the movement of the laser beam based on the model's first slice. For the formation of the next layer, the platform is lowered and fresh liquid resin runs

over the first layer, which is then solidified and attaches to the previous layer [8]. The more recent printing technique, known as micro-stereo-lithography, can produce layers up to 10 μm of thickness [3]. General applications of stereolithography in the medical field include surgical planning and training, dental models, surgical assistance, prosthetics, dentures, implants, hearing aids, bio manufacturing, tissue engineering, and regenerative medicine [10].

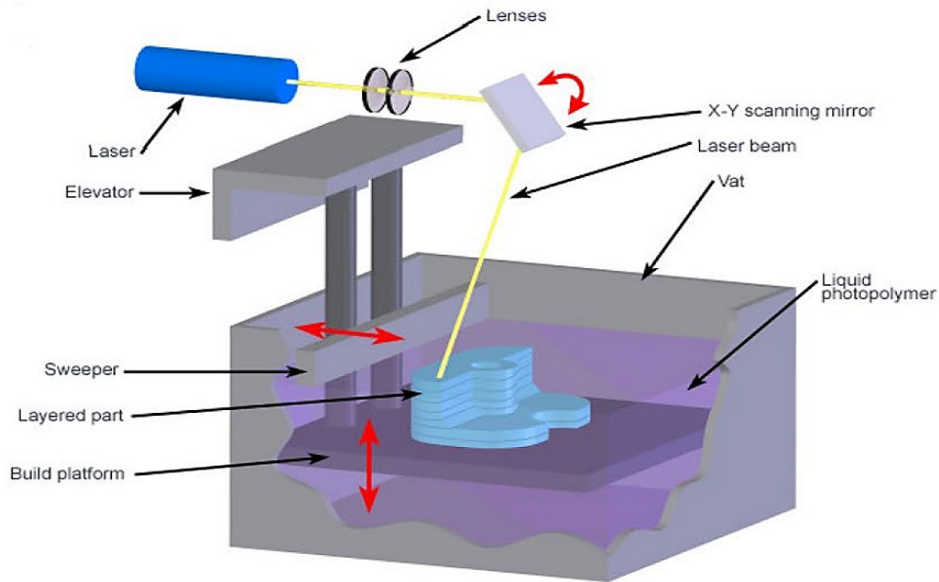

Fig. 5 Stereolithography (SLA) [2]

C. Fused Deposition Modeling (FDM)

On June 9, 1992, the Fused Deposition Modeling (FDM) invention was approved. This procedure, also known as fused filament fabrication (FFF), liquefies the polymer using a thermoplastic and a thermal chamber [2]. The extruder head can readily travel along the surface by virtue of x and y axes. Extruders are designed to deposit the

material layer by layer along with the shape specified by the computer; it finish the model by adding layers along with the z-axis, as shown in the figure below. The primary factors are the head and table temperatures, the scanning speed and path, and the wire speed. Acrylonitrile butadiene styrene and polylactic acid are the most frequently used as thermoplastics [3].

FDM is commonly utilized in the medical field to produce stiff and flexible anatomical models for surgery planning as well as scaffolds for cell growth, tissue, and organ development (soft tissues).

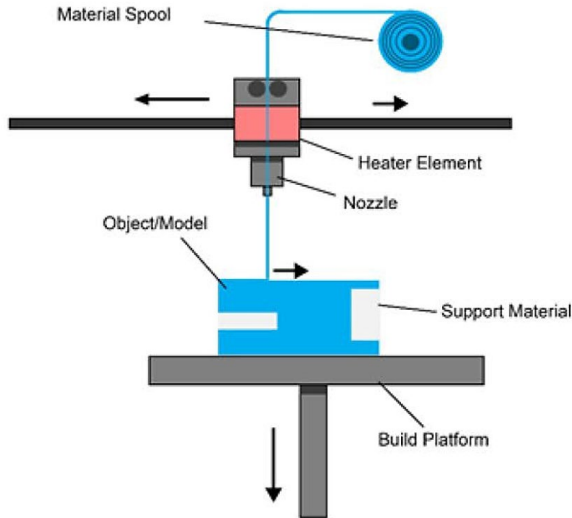

Fig. 6 Fused Deposition Modeling (FDM) [2]

D. Laminated Object Manufacturing (LOM)

This technology utilizes additive and subtractive methods to build the layers generated from adhesive laminate materials that have been laser-cut. In order to prevent mischief to the underlying material, the laser beam velocity and intensity are changed so that the depth of cut precisely matches the width of the layer [2]. Laminated Object Manufacturing is less expensive and easier to create large parts than other 3D printing technologies.

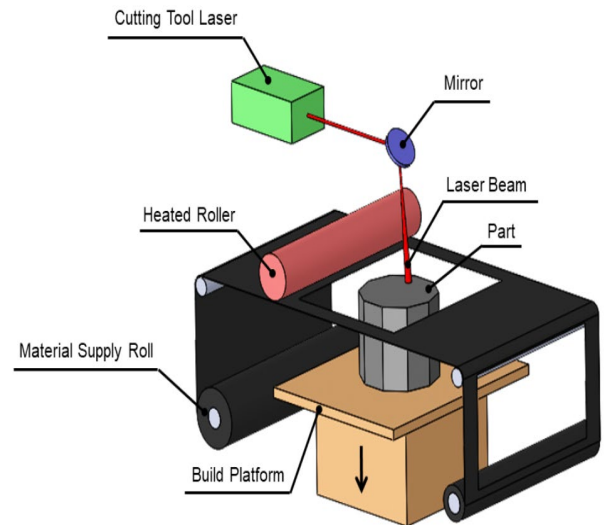

Fig. 7 Laminated Object Manufacturing (LOM) [2]

E. Electron Beam Melting (EBM)

Similar to SLS, it is a comparatively novel technique. An electron laser stream driven by high voltage, ranging from 30 to 60 KV, is used in this procedure to melt the powder. This procedure is used to create metal components, and it is carried out in an atmosphere to prevent rusting [3]. Comparatively other processes the Electron beam melting is quite expensive. For purposes like surgical planning and training, implants, orthoses, prostheses, surgical tools, tissue analogues for implantation, dental models, surgical guides, and restorations, the medical industry uses electron beam melting [10].

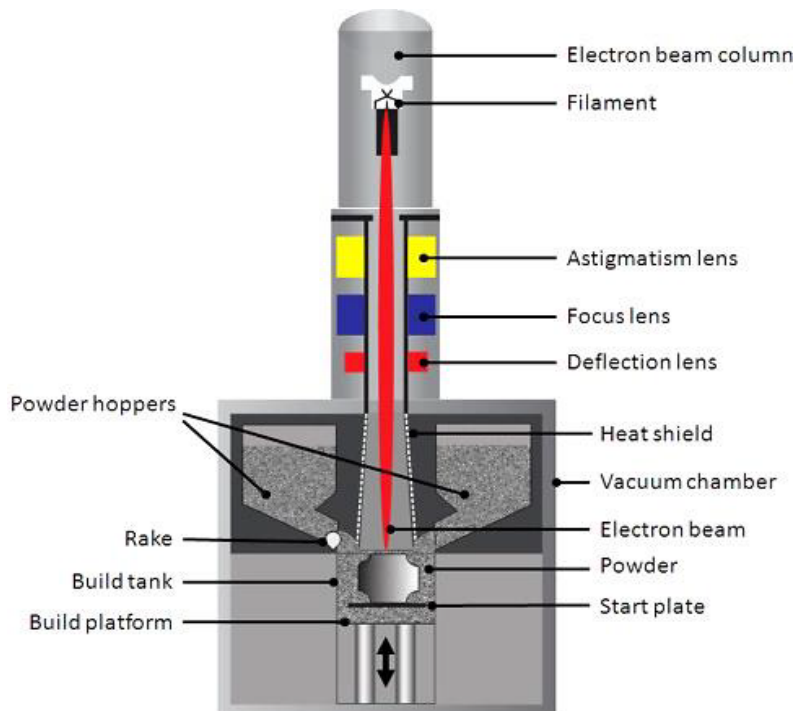

Fig. 8 Electron beam melting in biomedical applications [12]

VI. APPLICATIONS IN MEDICAL ADDITIVE MANUFACTURING

In the realm of scientific additive manufacturing, the paper examines several noteworthy applications. The figures below presented offers compelling visual proof of these applications, including coronary heart stenting to improve blood glide round organs, a hit results of bone fixation using custom-designed metal plates, threading, and screws, in addition to examples of implants utilized in general arthroplasty strategies for knee, elbow, ankle, shoulder, and hip. These illustrations effectively show the transformative ability of additive manufacturing in improving affected person outcomes and revolutionizing clinical treatments.



Fig. 9 Hip prosthesis (Parva stem implant) with EBM-made stem and acetabular cup [12]

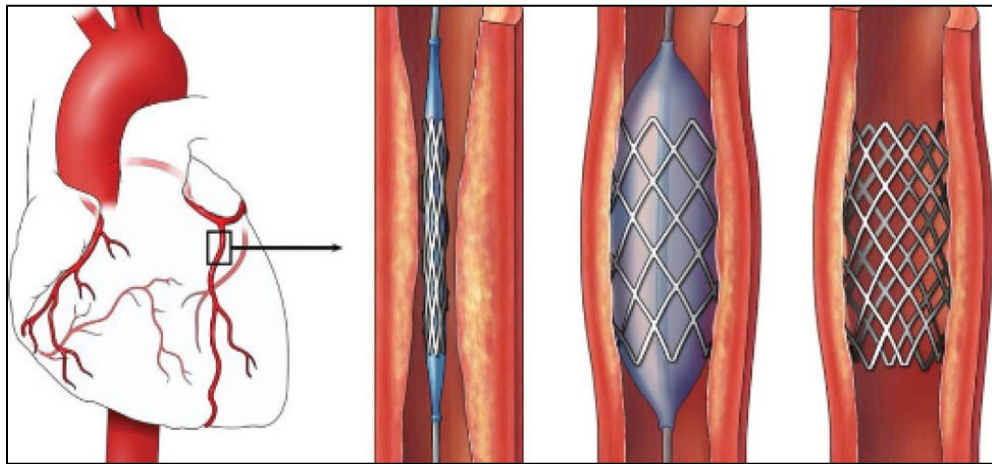

Fig. 10 Heart stenting to improve blood flow around organs [2]



Fig. 11 (a) Metal plates, threading, and screws used for bone fixation; (b) radiograph and outcome of tibial implantation of a fully recovered patient [2]

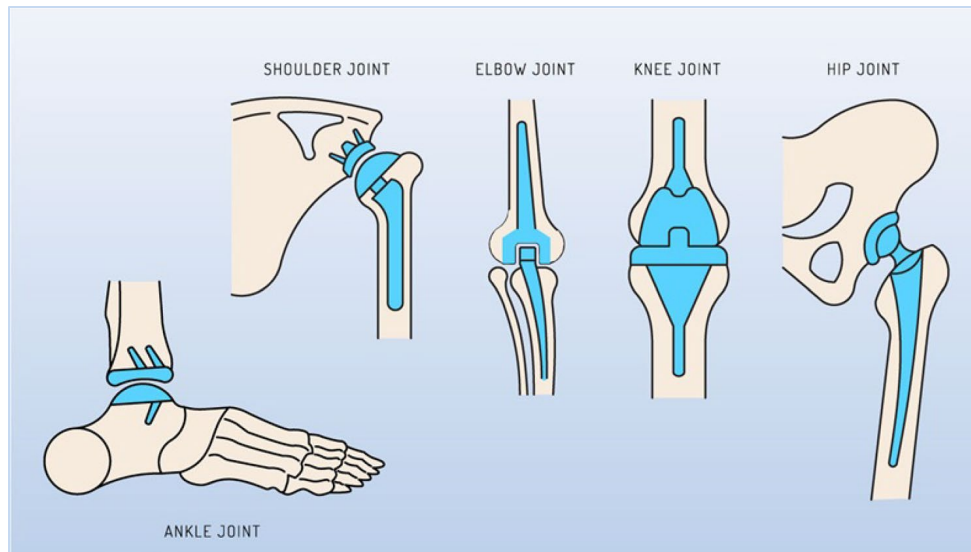

Fig. 12 Implant examples for total arthroplasty of knee, elbow, ankle, shoulder, and hip [2]

VII. CONCLUSION

This overview paper highlights the exceptional progress and transformative capability of clinical additive production. Over the past two decades, additive manufacturing technologies have evolved from growing easy anatomical models to generating complicated medical devices with precision and accuracy. The capability to print dwelling tissues and organs, layout custom implants and prostheses, and fabricate surgical gear has revolutionized healthcare and personalized medicinal drug. One of the key benefits of clinical additive production is its capability to create patient-specific answers that fit the man or woman's anatomy, leading to advanced patient results. In orthopedics and dentistry, this technology is extensively used to fabricate tailored implants and prostheses, enhancing the great lifestyles of patients. Moreover, using personalized anatomical models for pre-surgical making plans enables surgeons to exercise intricate strategies and reduce the chance of complications. The ability of three-D printing is going beyond the cutting-edge programs, as researchers are exploring novel medicinal drug shipping structures that could enhance treatment efficacy and affect a person's properly-being. The improvement of the bio-printing era, which allows for the advent of human organs without the want for donors, has the capability to revolutionize organ transplantation, addressing the vital scarcity of organs. Additionally, the combination of surgical robotics, synthetic through three-D printing techniques, offers a promising avenue to enhance affected person results and decrease dangers associated with traditional surgical methods. The collaboration between scientific professionals and robots holds the extraordinary capacity for boosting surgical precision and efficiency. Looking in advance, similarly, research and improvement efforts are vital to unencumber the whole potential of scientific additive production. Future improvements can also yield groundbreaking programs and improvements in regions which include regenerative medication, personalized drug shipping, and tissue

engineering. These ongoing efforts have the capability to reshape the panorama of modern remedies and provide progressive answers to complicated healthcare challenges. In conclusion, scientific additive manufacturing has come a long manner, and its adventure is a long way from over. By harnessing the electricity of three-D printing and its continuous improvements, we can expect a future where personalized medicinal drug and patient-particular treatments are the norms, leading to progressed affected person care and in the long run transforming the field of drugs as we comprehend it. Overall, medical additive manufacturing has the potential to transform healthcare by enabling personalized medicine, advancing tissue engineering, and improving medical education and training.

REFERENCES

- [1] Paritala, Phani Kumari, Shalini Manchikatla, and Prasad K. D. V. Yarlagadda, "Digital manufacturing-applications past, current, and future trends," *Procedia Engineering*, Vol. 174, pp. 982-991, 2017.
- [2] da Silva, Leonardo Rosa Ribeiro, Wisley Falco Sales, Felipe dos Anjos Rodrigues Campos, José Aécio Gomes de Sousa, Rahul Davis, Abhishek Singh, Reginaldo Teixeira Coelho, and Bhaskar Borgohain, "A comprehensive review on additive manufacturing of medical devices," *Progress in Additive Manufacturing*, Vol. 6, No. 3, pp. 517-553, 2021.
- [3] Ramola, Mukul, Vinod Yadav, and Rakesh Jain, "On the adoption of additive manufacturing in healthcare: a literature review," *Journal of Manufacturing Technology Management*, Vol. 30, No. 1, pp. 48-69, 2019.
- [4] Haleem, Abid, and Mohd Javaid, "3D printed medical parts with different materials using additive manufacturing," *Clinical Epidemiology and Global Health*, Vol. 8, No. 1, pp. 215-223, 2020.
- [5] Javaid, Mohd, and Abid Haleem, "Additive manufacturing applications in medical cases: A literature based review," *Alexandria Journal of Medicine*, Vol. 54, No. 4, pp. 411-422, 2018.
- [6] P. Mohit Chhaya, Patrina S. P. Poh, Elizabeth R. Balmayor, Martijn Van Griensven, Jan-Thorsten Schantz and Dietmar W. Hutmacher, "Additive manufacturing in biomedical sciences and the need for definitions and norms," *Expert review of Medical Devices*, Vol. 12, No. 5, pp. 537-543, 2015.
- [7] Mika Salmi, "Additive manufacturing processes in medical applications," *Materials*, Vol. 14, No. 1, pp. 191, 2021.

- [8] Marjan Bahraminasab, "Challenges on optimization of 3D-printed bone scaffolds," *BioMedical Engineering OnLine*, Vol. 19, No. 1, pp. 1-33, 2020.
- [9] Aamir Ahmed, Sandeep Arya, Vinay Gupta, Hidemitsu Furukawa and Ajit Khosla, "4D printing: Fundamentals, materials, applications and challenges," *Polymer*, Vol. 228, pp. 123926, 2021.
- [10] Ghomi, Erfan Rezvani, Fatemeh Khosravi, Rasoul Esmacely Neisiany, Sunpreet Singh and Seeram Ramakrishna, "Future of additive manufacturing in healthcare," *Current Opinion in Biomedical Engineering*, Vol. 17, pp. 100255, 2021.
- [11] Razavykia, Abbas, Eugenio Brusa, Cristiana Delprete and Reza Yavari, "An overview of additive manufacturing technologies - A review to technical synthesis in numerical study of selective laser melting," *Materials*, Vol. 13, No. 17, pp. 3895, 2020.
- [12] Nouri, Alireza and Antonella Sola, "Electron beam melting in biomedical manufacturing," In *Metallic Biomaterials Processing and Medical Device Manufacturing*, Woodhead Publishing, pp. 271-314, 2020.