

# Design and Fabrication of Thrower Mechanism for Multipurpose Ball Throwing Machine

Pankaj B. Gavali, Sujit S. Patil and Sanjaykumar M. Ingale

Assistant Professor, Department of Mechanical Engineering, Sanjay Ghodawat University, Kolhapur, Maharashtra, India  
E-mail: [pankaj.gavali@sanjayghodawatuniversity.ac.in](mailto:pankaj.gavali@sanjayghodawatuniversity.ac.in)

(Received 9 May 2022; Revised 20 June 2022; Accepted 16 July 2022; Available online 22 July 2022)

**Abstract** - The cricket and tennis are one of the popular games in the world. Nowadays the players are trained with the help of practice machine. To simulate different varieties of motions, speeds, and trajectories accurately and repeatedly, practice machine is designed by iterative design processes (manual calculations) with solid works. Two counter rotating wheel mechanism imparts both translational and rotational motions with spin. It is portable, flexible, run-on AC source, operated at various horizontal and vertical planes and desired combinations of both planes. This ball machine was constructed utilizing readily accessible components from the market. Because lowering manufacturing costs is one of the project's goals, the materials were chosen based on their reduced cost. Furthermore, the machine's parts are made of recycled and locally sourced materials. Therefore, after building is complete, this machine will be useful to many individuals, especially active gamers. The mathematical analysis for the design of a new tennis ball launcher in order to assess the possibilities for its technical implementation. First, traditional launchers are described. The motion equation of the flying tennis and cricket ball is formulated and numerically solved. This makes it possible to analyze the trajectories of the ball for different initial conditions: elevation angles, velocity of ball. Then, the mathematical analysis of the launcher with two counter rotating rollers is presented.

**Keywords:** Cricket, Tennis, Portable, Trajectory, Velocity

## I. INTRODUCTION

The globe over, ball throwing devices are favored by people who like cricket and tennis but who frequently travel. The device throws a lot of balls through a shot over the tennis net to the player who is waiting on the other side of the net or to the batter. They are typically used for training drills that involve straight, bounce, and yorker shots, either at the baseline or up at the net in tennis, or in cricket. There are a number of benefits to utilizing ball-throwing devices. The first benefit is that players will remain concentrated while practicing thanks to the machine. The portable ball machine correctly pitches the ball for the players in the manner they choose [1]. As a result, golfers will be able to smash the ball correctly without having to worry about what their training partner is doing since they can maintain their attention on their swing.

Additionally, players may programme their portable ball machine to feed and pitch the balls at the appropriate speeds for their skill level. Players have the ability to control how the balls are delivered to them, including how quickly they

are travelling toward them as well as their direction and trajectory. The machine is therefore appropriate for players of all skill levels. The ability of players to utilize a ball machine whenever and wherever they choose is its last benefit. They are portable, allowing athletes to exercise effectively whenever it is convenient for them without having to rely on anybody else [3].

### A. Ball Launcher

Tennis and cricket players are quite fond of tennis and cricket ball launchers. They utilize it to practice their strokes under various ball-related settings, including varying ball speeds, rotations, kinds of spin, and trajectory angles. There are primarily two types of tennis ball launchers on the market right now. They are mechanical and pneumatic launchers, respectively.

### B. Pneumatics Ball Launcher (Conventional)

To toss the ball, pneumatic launchers essentially employ compressed air. Utilizing a compressor, the air is compressed and kept in a chamber. To guarantee a decent trajectory for the tennis ball, the pressure of this compressed air is crucial. This is because the ball's initial velocity depends on the pressure of compressed air. While the ball is kept in a tube, the elevation angles of the tube may be changed to get different kinds of trajectory mechanisms. Both manual and automated electrical systems are available for setting the elevation angles.

By attaching an adapter at the end of the output tube, this pneumatic launcher may create a spin ball trajectory. This adapter causes the ball to revolve about the desired axis by slowing down one side of the ball. To obtain other sorts of ball spins, such as top spin, back spin, and slice ball, the adapter must be moved about the tube's axis. The spin velocity, however, cannot be adjusted independently because it is based on the throwing ball's beginning velocity. Typically, 230/110 V mains voltage is used to power pneumatic launchers. High durability, dependability, and tolerance to diverse weather conditions are benefits of pneumatic launchers. However, this kind of apparatus only encourages users to employ simple strokes, and complicated training cannot be carried out. Beginners should use it the most; amateur and expert players should avoid it.

### C. Mechanical Ball Launcher

To propel the balls, a mechanical ball launcher essentially employs two counterclockwise revolving rollers or wheels. Electric motors are typically used to rotate these wheels. The wheels' rotational speed affects the ball's initial velocity. The approaching ball is affected by the tiny openings between the wheels. The ball exiting the ball feeder is subsequently compressed by the wheels' extreme pressure and speed. The wheels then accelerate and apply tremendous pressure to propel the ball. Its launching mechanisms perform yawing (move machine left and right) and pitching (move pipe up and down) for various ball trajectories. Changing the rotational speeds will allow this device to spin the ball trajectory of both wheels. Top spin balls will be produced if the upper wheel is rotating more quickly than the bottom wheel. The ball ejects with back spin if the lower revolving wheel is spinning more quickly than the top wheel. Since it may be utilized on courts without an electrical source or in the event of a malfunction, mechanical launchers are often powered by accumulators.

Although there is no uninterruptible functioning, utilizing accumulators has the drawback of limiting the utilization period. However, a mechanical launcher can perform better than a pneumatic launcher since it offers higher precision and a larger range of potential strokes. As a result, it is appropriate for both amateur and professional players and may be utilized in advanced training. Analyzing both launcher types reveals that mechanical launchers offer better parameters and more control potential than pneumatic launchers. The advantages of a mechanical launcher include increased beginning velocity, smooth and precise ball flight, and a launching mechanism with excellent repeatability. Additionally, it has greater throw control and can spin the ball in the desired direction. The ball struck by the compressed air rolls in an unanticipated way within the output tube when employing a pneumatic launcher. This will result in a number of issues, including decreased accuracy and repeatability, because it is difficult to regulate.

## II. LITERATURE REVIEW

Lisa Cooper *et al.*, [1] The varsity men's lacrosse team at the University of Michigan is designing a new training facility and would like to implement a programmable lacrosse ball launcher to simulate practice conditions for individual/small group training. The device should be able to launch balls at various speeds and angles input by the user from set locations within the facility. It consists of the design process, selected concept, analysis, testing, validation and verification that went into designing and building a prototype lacrosse ball feeding device. Motor selection for vertical rotation, vertical translation, and horizontal rotation were based primarily on the static loading characteristics of the launcher. Bipolar brushless DC motors (commonly referred to as stepper motors) were selected for all motion axes. They actually use several different programs running at the same time to control our machine. They also use several components. The first

component is the Arduino UNO microcontroller. They flashed GRBL firmware on to the Arduino to enable it to run with g-code compatible software. For the purpose of Expo, they thought it would be a good idea to run the machine with human input via a game controller. They used both a PlayStation 3 controller and Xbox 360 controller.

Abhijit Mahapatra *et al.*, [2] It deals with the design, modelling, and simulation of a cricket bowling machine with the use of computers. A pair of counter-rotating ball ejecting wheels are part of the proposed bowling machine. These wheels are supported by a base and rotate axially in the same plane with a distance between them that is smaller than the diameter of the ball being thrown. A bi-axial precision tilting mechanism supports the base. The line and length of the ball are controlled by accurately adjusting the delivery point of the ball with regard to two axes, or yaw and pitch, using this tilting setup. In order to simulate the various mechanical sub-assemblies of the proposed cricket bowling machine using ADAMS (Automatic Dynamic Analysis of Mechanical Systems) software, a virtual model of the machine has been created in CAD/CAE software. To assess the functionality of mechanical assemblies, motion simulation of key subassemblies such as two-axis tilting mechanisms and ball auto feeding mechanisms has been carried out. Early on in the development process, functional simulation of the machine using CAD/CAE tools is expected to eliminate defects and enhance product quality.

R. Yousefi Moghaddam *et al.*, [3] Tennis Robot is a kind of systems, which its design and manufacturing technology is defined in this paper. It is tried to explain the effective design parameters in short and show the application of them in fabricating the machine under a critical situation. Then according to the experimental results that are taken from the former version of the machine some fundamental replacements are done in the most of its accessories in order to provide some of the engineering viewpoints such as reliability, effectiveness and productivity. Based on the experimental results, it is tried to find a correction factor to predict the initial velocity of the thrown ball and the mean throwing angle. Also, some discussions are made according to find an agreement between the experimental and theoretical results. The mechanism provides a continuous range of ball feeding between 3 to 15 balls per minute (bpm). There's a small gadget for entering the ball into the ball directing throat. The distance between two wheels and the angle of the throwing ball can be adjusted together. The appropriate pressure and the angle of throw are two main factors in this machine. For the best efficiency it is very necessary to find the most optimum rate of these two factors. As it is realized in this study, based on the critical pressure of ball, the study focused on the optimal angle and range of throw.

Khairul Amzar Bin *et al.*, [4] Three alternative idea designs were created for this project. Every design has unique qualities. The best concept design for this project will be chosen using the Pugh Concept Selection Method. The finest

idea design was then chosen, which utilised rotating wheels. This tennis ball machine was built using readily accessible items from the market. Because lowering manufacturing costs is one of the project's goals, the materials were chosen based on their reduced cost. Additionally, recycled and local goods were used to make the machine's parts. This project constructs the entire tennis ball machine rather than just the thrower component. The throwing distance of the ball is here taken into account while building a thrower mechanism. The ball's height and length are combined to form the distance.

Dave Wolowicz *et al.*, [5] The project goal is to create a dog toy and consist of the circuitry, software, and hardware design process. The dog toy is an automated tennis ball throwing machine, it will throw a ball and feed the dog via a TCP/IP network. In this machine users can call the dog using recorded messages. The process can be seen via a camera mounted on the mechanism. All of the control will be done through a webpage interface. Users can connect the dog toy to their home network and interact with it via a web browser. Web applications are independent of operating systems. Users only require a web browser and a network interface card. Here comparison of different thrower mechanism is done. From this they used mechanical ball throwing machine.

S. Perumalsamy *et al.*, [6] There are many games played in the world. The Volleyball is one of the popular games in the world. In volleyball the practice machines are only develops the "Pass" skill to the players. This project consist automated volleyball machine was fabricated to develop the skill set of "Pass, Set, Attack, and Dig," to the players. In Volleyball, the ball motion involves aerodynamic and mechanic principles. It demands superior Bio-mechanical skills acquired by repeated practices. To simulate different varieties of motions, speeds, and trajectories accurately and repeatedly, an automatic volleyball practice machine was designed by manual calculations with solid works and AutoCAD. Two counter rotating wheel mechanism imparts both translational and rotational motions with spin. It was portable, flexible, battery powered which is suitable for outdoor conditions, operable at various horizontal and vertical planes and desired combinations of both planes. It was fully automatic for the ball feeder mechanism to make itself contained yet made economical by making the ball shooter mechanism partially automatic/manual. The model was validated. The volleyball practice machine was simple and user friendly, to assist in acquiring the required skills for a trainee independently or for a professional player to enhance his/ her skills. Mechanism is portable, a 12-volt rechargeable battery can be used as the power source. The two wheels are driven by two separate DC motors. The ball feeder also consists of a ball hopper where the balls are inserted into a basket, to allow the balls to drop into the wheel one at a time. Controllers are provided to switch the motors on, change the speed, and set ball release time intervals.

Krzysztof Wojcicki *et al.*, [7] This paper presents the mathematical analysis for the design of a new tennis ball launcher in order to know the possibilities for its technical

implementation. The motion equation of the flying tennis ball is formulated and numerically solved. This makes it possible to analyze the trajectories of the ball for different initial conditions: elevation and heading angles, as well as the rollers angle. Then, the mathematical analysis of the launcher with two counter rotating rollers is presented. Young's modulus and friction coefficients for the typical tennis ball have been determined experimentally. Based on these, initial conditions for the throw have been found, rotating speeds of the rollers and powers of the driving motors.

Mr. Eric Constancio Andrade *et al.*, [8] They employed a straightforward "pulley-belt mechanism" instead of overly complex electronics. The design uses four pulleys and a belt drive to rapidly direct the balls away from the machine. Two motors power the belt drives. Wheel ejection at high rotational speeds is prevented by the motor shaft being keyed to the wheel and secured by a locking screw. The bowling machine uses two 0.5HP DC brushless motors, with foot mounting arrangement. In this machine, the ball at entry gets gripped between the pair of belt drives which are being driven by the motors and are moving at the speed to which the ball has to be bowled. The ball accelerates and reaches the final velocity at the delivery end. The machine also will be able to provide spin deliveries by adjusting the orientation of the ball delivery system.

Jitendra Kumar *et al.*, [9] This machine is an automatic bowling machine. Term automatic is used because of machine does not require any person to constantly put balls into the machine therefore the need for an extra man to stand along with machine has overcome. It consists of two high speed DC motors. Two wheels are also brought in use, mounting over the motors. The whole setup placed over a tripod, whose height and angle of projection for bowling can be adjusted manually. The speed of the two motors for driving the wheels can be varied by using a pulse width modulation (PWM) with microcontroller. PWM is the process of switching the power to a device on and off at a given frequency. It has used L293D driver IC for the small motor and L298 with MOSFET control and with 5 heat sinks for the high speed two motors.

Tanakorn Tony Ontam *et al.*, [10] Sepak Takraw ball throwing mechanism is made to simulate different kinds of ball motion in the sport of Sepak Takraw. Transportable from one location to another location by vehicle. Able to contain up to 10 balls. Battery powered so that the machine can run without electrical outlet. A spin is produced when the two wheels spin at different speeds. The two counter rotating wheels need to provide some cushion of the ball to help propel the ball out but a hard solid wheel could break the ball so that pneumatic rubber wheels were selected as the wheel type so that the air pressure could cushion the ball and help avoid ball damage. A 12-volt rechargeable battery is used. The two wheels are driven by two separate DC motors connected to this battery. This horizontal angle changing feature is mounted to a U-shaped base which freely moves along a vertical axis.

### III. DESIGN AND FABRICATION

#### A. Wheel Rotational Speed [7]

Two counter-rotating wheels are utilized to expel the tennis ball from the launcher fig. 1. The feeder's ball is moving across the space between these two wheels. The wheels' two forces cause the ball to be pushed at a high rate of speed. The circumferential speeds of the wheels affect the ball's linear and angular speeds fig. 3.

During the toss, the ball's linear and rotational speeds were  $V$ ,  $\omega$ , respectively.  $V_1$ ,  $V_2$ ,  $\omega_1$ ,  $\omega_2$  are the wheels' circumferential and rotational speeds, respectively.

$r_w$  = wheel radius,  $r_l$  = deformed ball radius, and  $\Delta l$  = ball deformation brought on by wheel pressure

#### B. Motor Calculation [6]

1. Mass of the tennis ball = 125 gm
2. Shooting Wheel diameter = 340 mm
3. Shooting wheel mass = 1 kg
4. Ball velocity = 27.77 m/s

Calculation:

$$v = (v_1 + v_2) / 2$$

$$r_w = r_1 = r_2$$

$$\text{Assume } \omega = \omega_1 = \omega_2$$

$$v = \omega r$$

$$r_w = 170 \text{ mm}$$

$$\omega = v / r = 27.77 / 0.17 = 163.35 \text{ rad/s}$$

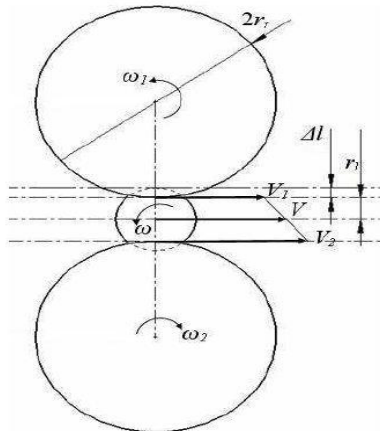

Fig.1 Two counter-rotating wheels

$$\text{Convert to RPM: } - \omega / 2\pi = 163.35 / 2\pi = 26 \text{ rps}$$

$$= 1560 \text{ RPM}$$

$$\text{Motor without load requires RPM} = 1560 \text{ RPM}$$

Assume that factor of safety of load acting in motor shaft is = 1.5

$$\text{Suitable motor speed to generate ball speed at } 27.77 \text{ m/s is}$$

$$= 1560 \times 1.5 = 2300 \text{ RPM}$$

$$= 2300 \text{ RPM}$$

$$= 240.85 \text{ rad/s}$$

Calculate the amount of kinetic energy for ejecting the ball at 27.77m/s:

$$\text{KE.b} = mv^2 / 2$$

$$= (0.125 \times 27.77^2) / 2$$

$$\text{KE.b} = 48.19 \text{ J}$$

Calculate the amount of energy stored in a shooting wheel:  
 $E_s = I\omega^2 / 2$

$$I = mr^2 / 2$$

$$= (1 \times 0.17^2) / 2$$

$$= 0.0145 \text{ kg.m}^2$$

$$E_s = 0.0145 \times 240.85^2 / 2$$

$$E_s = 420.56 \text{ J}$$

Where,

- $r_1, r_2$  = radius of shooting wheels
- $v_1, v_2$  = velocity of shooting wheels
- $v$  = velocity of the ball
- $\omega_1, \omega_2$  = angular velocity of shooting wheels

Calculate the total power needed:

$$\text{Total energy} = K_{eb} + E_s$$

$$= 48.19 + 420.56$$

$$E = 468.75 \text{ J}$$

$$\text{Power (P)} = E / t$$

$$= (6 \times 468.75) / 60 \text{ (assume 6 balls/minute to be ejected)}$$

$$P = 46.875 \text{ Watts}$$

Assume that the factor of safety is 1.5  
Therefore,  $P = 70 \text{ Watt}$

Similarly, for Lather Ball having 27.77m/s velocity and mass 150 gm power required to throw the ball is 72 Watt.

#### C. Wheel



Fig. 2 Wheel

The machine's wheel fig. 2 is a child's bicycle wheel. This wheel is conveniently offered on the market. It is lightweight and inexpensive. It is made of foam-coated plastic material with a plastic rim. By adopting this kind of wheel, we are able to achieve our goals of simple availability and affordable wheels. However, the wheels utilised in modern machinery are expensive and heavy. Concave surfaces are created on lathe machines for ball grasping. It yields positive results. The balls were thrown using two counter-rotating rollers or wheels. The ball is put under a great deal of pressure, causing it to throw quickly. Electric motors are typically used to rotate these wheels. The wheels' rotational speed affects the ball's initial velocity. The approaching ball is affected by the tiny openings between the wheels.

*D. Solid Works Design*

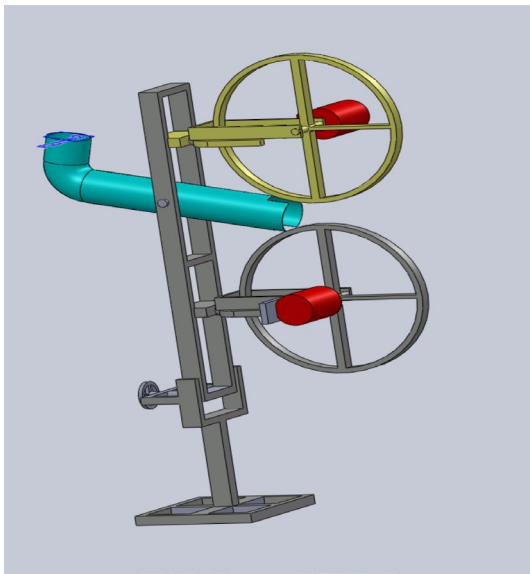

Fig. 3 Circumferential speeds of the wheels

**IV. FABRICATION**

Took two motor of sewing machine fig.4 AC motor of 50 watt each. It has regulator which control speed of motor. Maximum speed of motor is 2200 RPM.



Fig. 4 Motor

Motor requires coupling because it should be connected to wheel shaft. If there is rigid coupling and there are vibrations, fluctuation in machine then it will break. To avoid this, we used universal joint which will overcome this problem. The

motor shaft diameter is 6 mm and universal joint have 11 mm internal diameter. So, we used bushing for tight packing.

Bicycle wheels are used for this machine. These wheels having plastic spokes. These are coated with foam which gives cushioning effect such that it will provide adequate pressure as required and if hard wheels are used then it will break the ball.



Fig. 5 Wheel with internal curvature

These wheels fig.5 is coated with foam and to get good grip, internal curvature of small radius is produced. For this purpose, it was kept on the lathe machine and internal curve is produced. Now wheel is fitted on the shaft. Shafts are connected to two bearing of 6201. Shaft diameter is 9 mm, so bushing is required. It gives structural support. These bearings are welded to two iron plate for further fabrication.



Fig. 6 Wheel supported on bearing

In this machine lower wheel is fixed and upper wheel fig. 6 is sliding on same axis. For this sliding block is made. Mild steel rectangular block is used. The two circular discs are attached to two ends of the block such that block will slide on two rectangular pipes. Nut and bolts are used for tightening block to rectangular pipe. Fork is tightened to the block by nut and bolt. Second block on which lower wheel is attached, this block is welded to the rectangular pipe. Third block is like a first block to get different angular motions.



Fig. 7 Sliding block

This assembly is mounted two vertical rectangular pipes fig. 7. Motor is mounted on two different sides for balancing of machine.



Fig. 8 Assembly of parts

Upper wheel have up and down motion for setting of pressure, fig. 7 velocity of ball. It also helps in accommodating different diameters of the balls. This mechanism is done by pivoting the hinge. When small wheel is given rotary motion, screw moves in and out of the nut so that it applies pressure on hinge. Hinge is welded to the sliding block. When small wheel is rotated one rotation upper wheel either move up or down by 10mm.

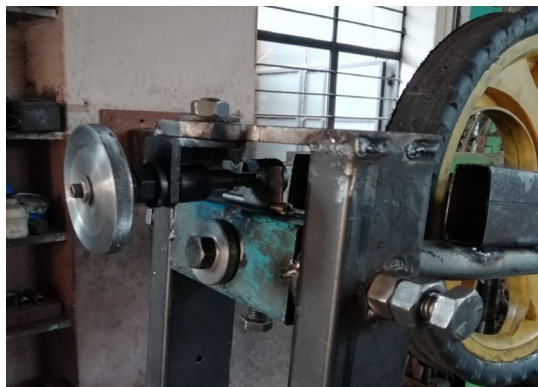

Fig. 9 Ball diameter adjuster

For adjustment of angle, fig. 10 mechanical linkage is done so that maximum 20-degree angle we can get. Inner rectangular bracket is pivoted to outer rectangular bracket at

second block. In this case when small wheel is rotated by one rotation then there will be change of 1 degree. This wheel is attached to the screw which slides in nut and block. For getting horizontal position of machine initial 4 degree are required.

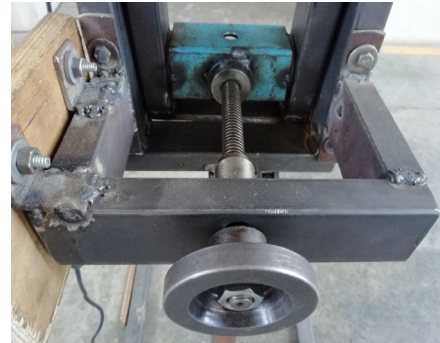

Fig. 10 Angle adjuster

This whole machine is welded to the rectangular pipe. This pipe has holes at a distance of 13 cm, for height adjustment of machine. Maximum height traveled by machine is 240 cm. Minimum height of machine is 136 cm.



Fig. 11 Machine height adjuster

Control panel consist of two controls. Each control having two speeds. Fig. 12



Fig. 12 Control panel

Pipe is placed at an inclined position at an angle fig. 13. It is clamped to machine. Pipe used is pvc pipe. It is fitted with elbow at one end and other end is cut in such way that it passes the ball at center of two wheels.



Fig. 13 Ball guider (Pipe)

## V. THEORETICAL CALCULATIONS

### A. Technical Requirements

Three key requirements must be established based on the research and analysis in order to create a tennis ball machine. They are the trajectory ball's height, its journey distance, and its trajectory speed. It is crucial to adhere to these requirements. In cricket, it's crucial to take into account how fast the ball is moving in the player's direction.

### B. Ball Specification

#### 1. Tennis Ball Specifications

Diameter: 62 mm  
Mass : 125 gm

#### 2. Cricket Ball Specifications

Diameter: 73 mm  
Mass : 150 gm

### C. Tennis

#### 1. Tennis Court Specifications

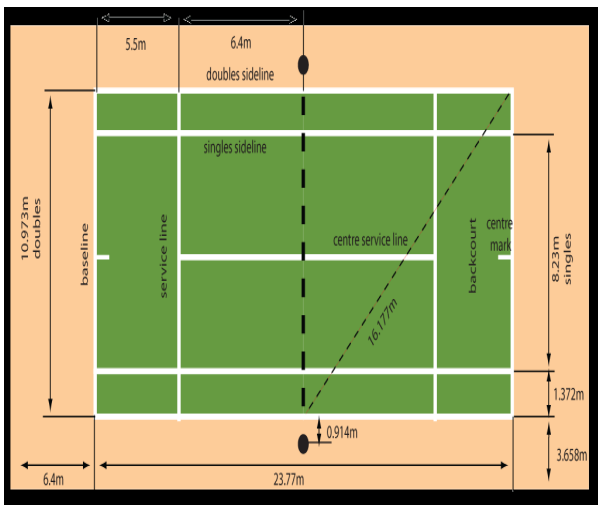

Fig. 14 Tennis court

### 2. Technical Specifications Summary

The height of the trajectory ball must be launched at a minimum height of 1.1 m once all the requirements and guidelines have been compiled fig. 14. This is due to the net being 1.07 meters high, which is the minimum criterion set out by ITF. If the tennis ball machine is placed directly behind the baseline, the ball must travel a minimum of 23.8 meters and no more than 12 meters. The ball's trajectory speed is designed to have an average speed of 100 km/h.

### 3. Calculations

In general, the tennis ball machine's thrower mechanism works well. According to the previously mentioned technological requirements, it can toss the tennis ball. Three important aspects are considered to guarantee the thrower mechanism functions properly. The ball's throw distance, the wheels' rotational speed, and the motor's power are the determining elements.

#### 4. Throwing Distance of the Ball

The throwing distance of the ball is the first aspect that needs to be taken into account while building a thrower mechanism. The ball's height and length are combined to form the distance. Projectile motion was a notion employed in this system. The theoretical calculation of projectile velocity is taken into consideration in order to examine the distance travelled by the ball after being launched from the revolving wheels.

#### 5. Theoretical Calculation [4]

According to prior research and analysis, the tennis ball machines on the market have a ball speed range of 20 to 150 km/h. Therefore, for the sake of this research, an average ball speed of 100 km/h is considered. The ball launcher is positioned 1.36 meters above the ground. To get the overall height the ball has travelled, the height the ball has travelled must be added to this figure. This tennis ball machine's thrower mechanism is calculated using six elevation angles. The angles of elevation are 2, 5, 6, 8, 10, 12, 14, and 16 degrees. The results are as shown below.

#### a. Ball Travel Distance

- i.  $L = (V^2 \sin 2g) \text{ length}$
- ii.  $g = 9.81 \text{ m/s}^2$  and  $V_0 = 100 \text{ km/h}$

TABLE I LENGTH TRAVELED BY BALL

Elevation Angle (°)	Thrown Length (m)
2	5.48
5	13.66
6	16.34
8	21.66
10	26.88
12	31.97
14	36.90

The tennis court is 23.77 meters long in total. This calculation demonstrates that, if the tennis ball machine is positioned just behind the baseline, the ball can pass through the net of the tennis court starting at an elevation angle of 5.0°. Around 12 meters separate the baseline from the net. As long as the tennis ball machine can be changed to be put farther beyond the baseline, even though the thrown length at a 14.0° elevation angle surpasses the length of the tennis court as a whole, this project is unaffected. This may cause the thrown ball to land directly on the other side.

*b. Ball Height Travelled*

- i. Height,  $H = (V^2 \sin^2(\alpha)) / 2g$  plus 1.36
- ii.  $g = 9.81 \text{ m/s}^2$  and  $V_0 = 100 \text{ km/h}$

TABLE II HEIGHT TRAVELED BY BALL

Elevation Angle (°)	Thrown Height (m)
2	1.4
5	1.65
6	1.78
8	2.12
10	2.55
12	3.06
14	3.66

The tennis net rises 1.07 meters above the ground. This calculation demonstrates that, if the tennis ball machine is positioned just behind the baseline, the ball may cross the tennis court beyond the net at an elevation angle of 2.0°. The project is unaffected by the high throwing height at 14.0° elevation angle because there is no height restriction at the tennis court. It doesn't matter if the ball is thrown higher as long as it lands directly on the other side.

*D. Cricket*

*1. Cricket Pitch Specification*

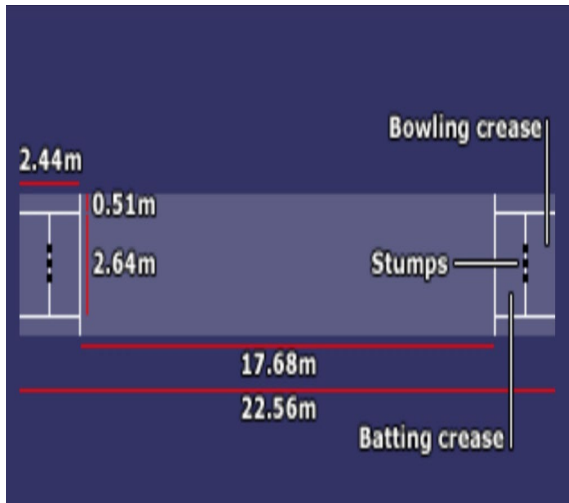

Fig. 15 Cricket pitch

The size of the field on which game is played varies from ground to ground but the pitch is always rectangular area of 22 yards (20.12m) in length and 10ft (3.05m) in width fig. 15. The batting crease is marked 1.22m in front of stumps at either end, with the stumps set along bowling crease. The return creases are marked at right angles to batting and bowling creases and are measured 1.32m either side of the middle stumps.

*2. Calculation [11]*

Pitch length – 20.12m  
 Velocity – 100km/hr.  
 $g = 9.81 \text{ m/s}^2$

Height from ground to center of rollers - 1.5m  
 Time required to reach the ground- t  
 Angle between center of two wheels with respect to horizontal line –  $\alpha = 1^\circ$   
 Height of the ball from center of rollers – H

$$H = \frac{v^2 \sin^2 \alpha}{2g}$$

$$= \frac{27.77^2 \sin^2(1^\circ)}{2 \times 9.81}$$

$$= 0.011 \text{ m}$$

Maximum height travelled,  $S = 1.5 + 0.011 = 1.51 \text{ m}$   
 Time taken by the ball to reach maximum height from center of rollers,

$$t_1 = \frac{v \sin \alpha}{g}$$

$$= \frac{27.77 \times \sin(1^\circ)}{9.81}$$

$$= 0.05 \text{ sec}$$

Time taken by the ball to reach ground from maximum height,

$$S = ut_2 + 0.5gt_2^2$$

$$1.51 = 0 + 0.5 \times 9.81 \times t_2^2$$

$$t_2 = 0.55 \text{ sec}$$

Total time  $t = 0.56 \text{ sec}$   
 Range,  $R = \text{Horizontal component of velocity} \times \text{time}$   
 $= 27.77 \times \cos(1^\circ) \times 0.56$   
 $= 15.55 \text{ m}$

From above calculation it is concluded that by changing the inclination angle and velocity we can get variable ranges such as Yorker or bounce.

*E. Calculation of Force on Ball*

Impulse momentum principle: The net impulse on an object is equal to change in momentum of object.

Where,  
 $J$  – Net impulse on object  
 $\Delta P$  - Change in momentum of object  
 $F$  – Avg. force on the ball.  
 $\Delta t$  - Time that ball is in contact with wheels at that velocity  
 $J = \Delta P$   
 $F \Delta t = \Delta P$



$$\begin{aligned}
 F_{avg} &= \Delta p / \Delta t \\
 &= (mv - 0) / \Delta t \\
 &= (0.065 \times 27.77) / 0.012 \\
 &= 150.42 \text{ N}
 \end{aligned}$$

Therefore, by increasing velocity of ball force required is high.

## VI. TESTING

### A. Velocity Calculation

Assume that both wheels have same speed that is 2200 RPM  
 $N = N_1 = N_2 = 2200 \text{ RPM}$   
 $\omega = \omega_1 = \omega_2 = 2 \pi N / 60$   
 $= 2 \pi * 2200 / 60$   
 $= 230.38 \text{ rad/s}$   
 $v_1 = v_2 = r \omega$   
 $= 0.17 * 230.38$   
 $= 39 \text{ m/s}$   
 Therefore, velocity of ball  
 $v = (v_1 + v_2) / 2$   
 $= 39 \text{ m/s}$   
 $= 140 \text{ km/hr}$

### B. For Cricket

Total length = 17.67 Meter  
 1. Upper wheel speed = 1500 rpm  
 Lower wheel speed = 2200 rpm  
 Angle = 10 degree  
 Clearance Between wheels = 0.045 m  
 Distance from center of the wheel to ground = 1.67 m

From this input data, got ranges of the ball in meters, 17, 17, 18, 17, 18.

2. Upper wheel speed = 2200 rpm  
 Lower wheel speed = 1500 rpm  
 Angle = 10 degree  
 Clearance Between wheels = 0.045 m  
 Distance from center of the wheel to ground = 1.67 m

From this input data, got ranges of the ball in meters, 17, 16, 16, 16, 16.

3. Upper wheel speed = 2200 rpm  
 Lower wheel speed = 2200 rpm  
 Angle = 9 degree  
 Clearance Between wheels = 0.045 m  
 Distance from center of the wheel to ground = 1.67 m

From this input data, got ranges of the ball in meters, 16, 16, 16, 17, 17.

4. Upper wheel speed = 1500 rpm  
 Lower wheel speed = 2200 rpm  
 Angle = 8 degree  
 Clearance Between wheels = 0.045 m

Distance from center of the wheel to ground = 1.77 m

From this input data, got ranges of the ball in meters, 15, 15, 15, 15, 16.

### C. For Tennis

Total pitch length = 23.8 m  
 Net height from ground = 1.1 m

1. Angle = 6 degree  
 Distance from centre of the wheel to ground = 1.77 m  
 Clearance Between wheels = 0.04 m

TABLE III TENNIS BALL RANGE (1)

Speed(rpm)	Range(Meter)
Lower wheel = 2200 Upper wheel = 2200	20.42
Lower wheel = 1500 Upper wheel = 2200	16.45
Lower wheel = 2200 Upper wheel = 1500	17.37

2. Distance from centre of the wheel to ground = 1.77 m  
 Clearance Between wheels = 0.04 m  
 Lower wheel speed = 1500 rpm  
 Upper wheel speed = 1500 rpm

TABLE IV TENNIS BALL RANGE (2)

Angle (Degree)	Range (Meter)
8	18.59
10	19.50
12	20.11

3. Angle = 4 degree  
 Distance from centre of the wheel to ground = 1.36 m  
 Clearance Between wheels = 0.04 m

TABLE V TENNIS BALL RANGE (3)

Speed	Range(m)
Lower wheel = 1500 Upper wheel = 1500	Ball is on the net
Lower wheel = low Upper wheel = high	Ball is on the net
Lower wheel = high Upper wheel = high	21.33

## VII. RESULTS OF THE STUDY

For Cricket and Tennis:

Velocity of the ball can be varied by changing speed of the wheel using speed controller, or by changing center distance between two wheels. Yorker or bounce ball can be get by changing inclination angle. When all initial conditions are

kept constant then ball will drop within range of 1.5m rather than at same point. By changing height of the machine various ranges ball can be achieved.

Ball will go beyond the net after 4 degrees otherwise it will be on the net. At 4 degrees, both wheels rotating at high speed then only ball will go beyond the net. By increasing inclination angle ball range increases linearly.

### VIII. CONCLUSION

Making the equipment to be used for fielding, cricket, tennis, and practice. Within the constraints of the current design, a holding and sliding mechanism is given to adjust the position of the wheels with relation to one another in order to hold and throw various types of balls, such as tennis and cricket balls. The following benefits of the suggested device: The bowling pace can fluctuate between 70 and 140 kilometers per hour. Repeatability allows for positive line and length adjustments in bowling. Tennis balls and cricket balls of various sizes can be tossed successfully. Transporting the apparatus to and from the working site is made easier by the lightweight, streamlined structure that has already been discussed in this article. The length of the bowling, from bouncer to yorker, may be changed by altering the pitching angle to suit the batsman's preferences. One can obtain the accuracy and repeatability of ball pitching distance needed for efficient batting practice by using simulation under the right input circumstances. The flying ball model that is being described is relatively straightforward, yet it nonetheless makes it possible to accurately examine the trajectory of the ball under various beginning circumstances.

### REFERENCES

- [1] Lisa Cooper, Peter Gerow, Tyler Huntress and Gulam Islam, "Final Written Report Team 00LAX: Lacrosse Ball Feeding Device," Mechanical Engineering, Department The university men's lacross team at university of Michigan, 9 April 2015.
- [2] Abhijit Mahapatra, Avik Chatterjee and Shibendu Shekhar Roy, "Modeling and Simulation of Cricket Bowling Machine," *International J. of Recent Trends in Engineering and Technology*, Vol. 3, No. 6, May 2010.
- [3] R. Yousefi Moghaddam, M. Alitavoli, A. Chaibakhsh, A. Rezaiefar and A. Bagheri, "Fabricating a tennis robot based on the counter rotating wheels," Department of Mechanical Engineering, Guilan University, Rasht POBox 3756, Iran.
- [4] Khairul Amzar Bin Mohd Kassim, "Design and Fabrication of Thrower Mechanism for Tennis Ball Machine," Bachelor of Mechanical Engineering (Automotive), University Teknikal Malaysia Melaka, pp. 1-42, 2013.
- [5] Dave Wolowicz, Marlene Bothe and Gordon Faus, "Progress report on an automated Dog ball tossing machine," University of Victoria Electrical Engineering.
- [6] S. Perumalsamy, P. Ragupathi and K. R. Rahul, "Design and development of volleyball practice machine," *International Journal of Latest Trends in Engineering and Technology (IJLTET)*, Vol. 4, No. 1, May 2014.
- [7] Krzysztof Wojcicki, Kazimierz Pucilowski and Zbigniew Kulesza, "Mathematical analysis for a new tennis ball launcher," Bialystok University of Technology, Faculty of Mechanical Engineering, ul. Wiejska 45C, 15-351 Bialystok, Poland.
- [8] Mr. Eric Constancio Andrade, Mr. Hansie Roger Pinto, Mr. Nikith M. and Mr. Sanjay Jacob, "Design and fabrication of belt-drive cricket bowling machine," St Joseph Engineering College, Project Ref. No: 38S0734.
- [9] Jitendra Kumar, Sanchit Sharma, Paramjeet Singh and Vaibhav Tewatia, "Design and experimental analysis of automatic bowling machine," *MIT International Journal of Mechanical Engineering*, Vol. 5, No. 2, pp. 88-92, August 2015.
- [10] Tanakorn Tony Ontam, "Automated sepak takraw ball throwing mechanism for training," Tanakorn Tony Ontam B. E., Khon Kaen University, 2000 B. S., California State University, Sacramento, Master's Thesis, 2008.