

Design and Analysis of Lower Limb Assistive Exoskeleton

J. Keerthana, R. Harish Krishna, R. Hariharan, M. Krishnamoorthy and E. Kumaresan

UG Student, PSG College of Technology, Coimbatore, Tamil Nadu, India

E-mail: jayakumarkeerthana8@gmail.com, harish.mar01@gmail.com

(Received 19 January 2022; Accepted 2 March 2022; Available online 8 March 2022)

Abstract - Assistive Exoskeleton is a type of ergonomic product that is based on exoskeleton support and is a chair. Standing for five hours or more each day, according to a small study, increases the risk of considerable and prolonged lower-limb muscular fatigue. Long-term back pain and musculoskeletal problems may be increased as a result of this. Meanwhile, the researchers discovered that persons who primarily stand at work are several percent more likely than “predominantly sitting populations” to suffer heart disease. Because of its big size, high weight (5 to 7 kg), and hard frame, the traditional chair is inconvenient to transport to different working locations. As a result, they are unsuited for workplaces with limited space. Because lightweight members are used, the flexible wearable chair may have a gross weight of 3 kg. It has to be constructed in such a way that workers may be comfortable while performing their activities and can adjust their sitting posture to any angle between 90 and 160 degrees. This exoskeleton can be used as an extra pair of legs to allow a person to sit without using a chair or to adopt a more comfortable position for certain occupations. Workers can walk around normally, but they must adjust and secure the supporting structure in the proper position if they want to sit or lean. The weight is then balanced on the floor by their movable frames. It's designed for factory workers who must stand for extended periods of time in work and occasionally bend into unusual positions to build a product. Spatial management is a critical aspect in every industry. By optimizing the utilization of an Assistive Exoskeleton, superfluous chairs and resting areas can be avoided.

Keywords: Ergonomics, Chair Less Chair, Exoskeleton, Productivity, Adjustable Sitting Positions, Excessive Standing, Exoskeleton Structure, Health Risk

I. INTRODUCTION

Ergonomics is a field of science that aims to better understand people's strength and capabilities in order to enhance their relationships with products, systems, and environments. Ergonomics strives to improve work conditions and workspaces in order to reduce the risk of accident or harm [1]. As technology advances, so does there is a need to ensure that the tools we use for work, rest, and pleasure are intended to meet the needs of our bodies. Human movement has been aided by exoskeletons, which can also be used for medical rehabilitation. Exoskeletons have become increasingly useful in the field of medical rehabilitation, and some very compact powered exoskeletons for mobile applications have recently been demonstrated, but the period of use is generally limited due to battery constraints. People who carry loads may benefit from a leg exoskeleton because it increases load capacity,

reduces the risk of leg or back injury, improves metabolic motility economy, or reduces perceived effort [2].

There are two types of exoskeletons: Exoskeletons are divided into two categories: active exoskeletons and passive exoskeletons. Exoskeletons that are active are powered by external factors such as a motor or batteries. They work in tandem with the passive exoskeletons to aid with their operation. Exoskeletons that are powered by mechanical linkages, pneumatic and hydraulic mechanisms, spring-controlled devices, and other mechanisms rather than external power sources. We've concentrated solely on passive types of exoskeletons because active exoskeletons limit the amount of external energy that can be given in terms of quantity, quality, and time. Passive elements are used in the exoskeleton to either store or dissipate energy, with the goal of lowering the amount of energy required for locomotion by the human. This contraption, which we refer to as a chair less chair, is lighter than a regular chair and is also more mobile and portable [3].

On a person's lower body part, a virtual chair that resembles an exoskeleton can be worn. He/she can move and sit anywhere and whenever he/she wants with the help of this. The usage of chair less chairs is anticipated to reduce the number of occurrences of MSD (Musculoskeletal Disorders) that occur in workers who spend lengthy periods of time standing [4]. While you use this gadget, you can walk or even run as needed, but you will be locked into a supporting structure when you sit at various angles. The goal of this project is to design and build a low-cost lower body exoskeleton, or, to put it another way, a chair less chair gadget. This project can assist users improve their posture, sit comfortably anywhere, and relax their leg muscles. This approach helps workers maintain a standing position while also allowing them to relax their legs. The aim of this work is to design and analyze the lower limb assistive exoskeleton for the use of industry workers.

II. LITERATURE REVIEW

A mechatronic wearable posture aiding device that includes a damper with connectors for pivotably connecting the damper to the support, a relatively high assistance for integrating to someone's lower leg, a lower support for connecting to someone's shank, and a joint pivotably connecting each support [1]. The foundation of support and the center of gravity of the erect human body. Another way

of describing forward and backward leanings of a straight human body with its feet planted on the ground. The stability of the upstanding human body during static balancing motion is determined by essential characteristics such as the locations X Centre of Gravity and Y Centre of Gravity of the body's focal point of gravity in the upstanding posture, as well as the range R of the base of help [2].

Current product design strategies simplify the complex needs of the human upper limb, risking the wounded patient's recovery and safety. Early in the design process of a rehabilitation robotics machine, it is critical to address the consumer needs and requirements. They learn how to evaluate a person's desire to engage in the design of a wearable robot for Filipino and Asian patients' rehabilitation. The outcomes of the research and subsequent discussion were compiled into a list of consumer criteria for wearable robots in neurorehabilitation [3]. Many people with spinal injuries are confined to wheelchairs, leading to a sedentary lifestyle that leads to secondary diseases and increased reliance on a job.

Although there is growing evidence that locomotor training decreases the frequency of these secondary diseases, the physical effort involved in this teaching is such that compliance is poor. The control of a novel "human friendly" orthosis (exoskeleton) and diagram, driven by high strength pneumatic Muscle Actuators, is described in this study (PMAs). For paraplegic patients, the combination of a highly supple actuation system with a sophisticated embedded control mechanism that monitors hip, knee, and ankle locations, velocity, acceleration, and force delivers powerful yet fundamentally safe operation [4].

Because the exoskeleton-based hydraulic support is so light, it creates very little hindrance when walking, and the user quickly becomes accustomed to it. During the testing of the chair while performing some work, it was discovered that they had difficulty altering the chair's degree level [5]. It includes kinematic setups, which enable stopping between constant qualities at any working role along these lines, in contrast to the standard seat. It is designed to significantly reduce the risk of body musculoskeletal problems among industrial employees. It uses ANSYS programming to focus on the mechanical form and limited thing investigation (FEA) of the instrument [6]. A quantitative approach to evaluating human biomechanics, demonstrating classical mechanics standards while incorporating contextual research such as human growth. The movement of articles is shown using vector variable-based arithmetic and vector separation, and 3D movement mechanics are represented both inside and out. Human growth is depicted using graphs and programming-generated categories [7].

Wearable gadgets improve labor efficiency while lowering tiredness levels [8]. The lower limit exoskeleton is a wearable automated device that should enable a human to walk with a heavy load for an extended period of time

without losing agility. Two human legs and a spine make up the exoskeleton, which provides an adaptive stacking interface. The device should be built and regulated in such a way that the human may perform a variety of workouts without feeling the device [9]. The design structure for controlling the human exoskeleton. These sorts of gadgets, which have an ergonomic basis, may be readily changed with the application of more recent technologies, combining several facilities into one body, and being regularly modified. It has numerous key uses in a real-time setting, such as wearing it on packed trains or in public locations with limited room [10].

A leg system has been conceived as a kinematic structure whose mechanical plan may be used by representatives as a wearable exoskeleton by referencing to human seats and strolling. The body can reasonably sustain the 100 kg of human body weight, according to the Specified Design specifications. Oil was also added to the weight-continuing system in the later stages to save costs, resulting in greater results. These types of devices with ergonomic foundations may be efficiently refurbished with the use of more advanced technologies, bringing all of the offices together into one body and being constantly changed. An important concept for how a Pneumatic or Hydraulic Cylinder exoskeleton might be used to reduce fatigue by leveraging fundamental kinematic components [11].

In 1977, a wearable chair allowed individuals to sit on two legs, which was previously unthinkable. However, the design proposed by them using their methodology has some flaws, including the following: it only allows for one sitting position, regardless of the user's preference, and it places a significant amount of stress on the lower leg as a result of the response pressure imposed by the decrease bar. However, the technique has certain ergonomic issues; the most significant issue with such a design is ensuring that workers may move freely and that they are in a stable balance after sitting [12].

Much has been written on the effects of a little leg length imbalance on stance and stride. Many arguments have been made in favor of and against the need for intervention to reduce the extent of the discrepancy. Their study emphasizes the need of accurate and trustworthy leg length contrast assessment employing a therapeutically useful radiography technique, as well as the biomechanical implications of leg length difference as linked to the alleviation of stress cracking, low back pain, and osteoarthritis [13]. This is a small introductory soft cover that explains how to apply material science knowledge to the study of living structures and delivers content in a straightforward manner that requires little or no prior knowledge of physical science or science [14]. Exoskeletons, for example, are capable of providing therapeutic improvement and autonomy to persons with musculoskeletal diseases. Ordinary devices rely on either dynamic assistance tactics, such as DC engines, or passive ones, such as springs, hole valves, or switches. Afraid

approaches are limited by client capacity, whereas dynamic solutions demand a constant power input. An Active/Passive Exoskeleton system is presented in this paper. This device can provide unending assistance by just waiting for vitality to modify the dynamic features of the inactive condition [15].

A. Need for the Exoskeleton

We can't use our usual chair in certain places since it looks strange or there isn't enough room. In such cases, a chair-less chair will be the appropriate tool. Those who suffer from severe, ongoing back discomfort might benefit from this chair. This will be the best solution for people who are unable to sit. Factory employees who must stand for lengthy periods of time might also benefit from it [5]. It's an exoskeleton model that humans can wear. If a person stands for a long time, he or she will grow weary and unable to finish the remaining duties.

However, if they use a chair less chair, they may sit anywhere they choose, conserving energy and allowing them to do their tasks completely, enhancing the productivity of the firm or industry in which they work. It occupies a small amount of space and can be used practically anyplace. It includes a wide range of programmed to choose from, and the user has total freedom over what he or she uses. It is particularly cost-effective because it is constructed of recyclable materials and can be used by a wide range of individuals.

B. Problem Statement

The seat is insufficient when we want to sit wherever and at any time. It might be challenging to provide chairs in every field of vision for all personnel. Excessive sitting is bad because it affects the metabolic rate of the body, increasing the risk of diseases including hypertension, diabetes, cancer, and depression [6]. Excessive standing, on the other hand, has the most detrimental effects on one's health. The major purpose of workstations is to boost productivity, however the impact of job strain on the worker's body is rarely considered. Despite the fact that the work environment is ergonomically designed, it fails to alleviate laborer tiredness since they are compelled to work in the same position for lengthy periods of time [7].

C. Objectives of the Study

The basic goal of the exoskeleton is to

1. Assist workers in reducing the microgravity of their bones and muscles caused by prolonged standing.
2. Encourage injured workers to return to work as soon as possible.
3. Provide all workers in an industry with mechanical ergonomic devices that can be used even in small places.

4. Design and build a low-cost assistive gadget that allows regular walking and running movements.
5. When we wear it, it should also allow us to move around.

III. RESULTS AND DISCUSSION

A. Methodology

The design development of the product has been carried out by the following methodology as shown in the figure 1 which is done in a stepwise manner.

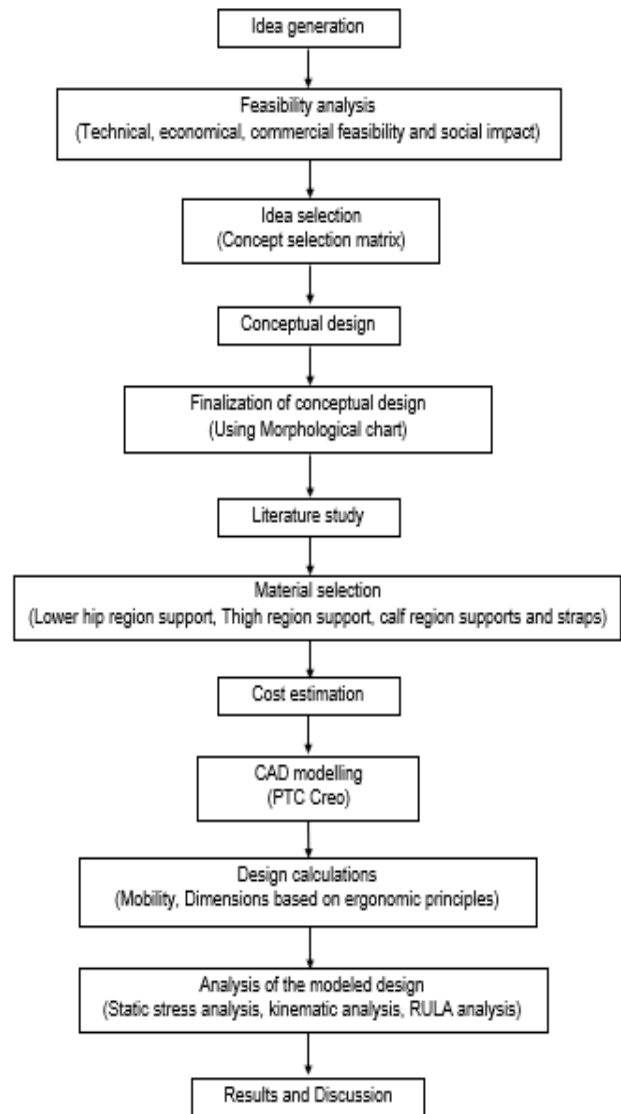

Fig. 1 Methodology for Lower limb assistive exoskeleton

B. Conceptual Sketches

The conceptual sketches were made as a part of brainstorming and in order to finalize the better design one among them as shown in the figures 2-6 and the reference design is shown in the figure 7.

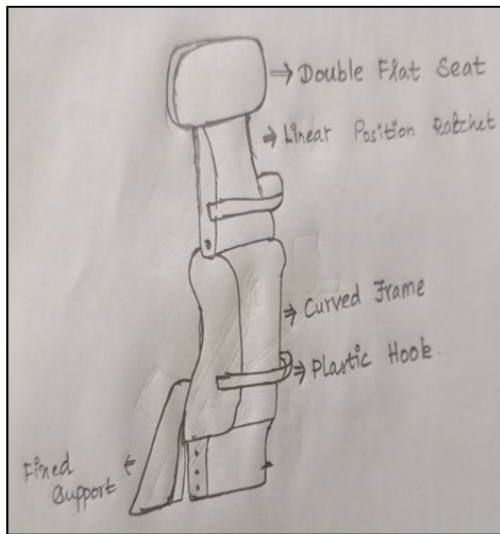

Fig. 2 Concept A

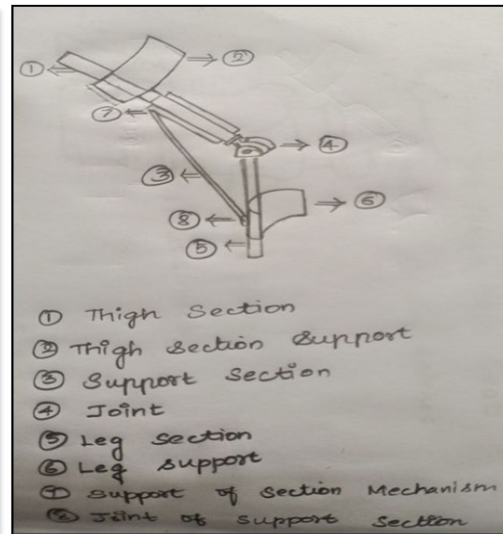

Fig. 3 Concept B

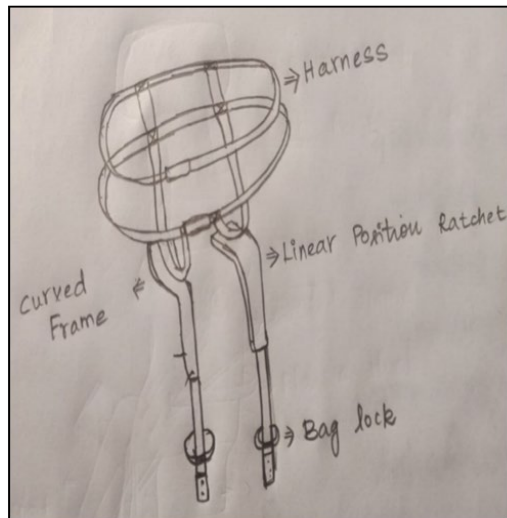

Fig. 4 Concept C

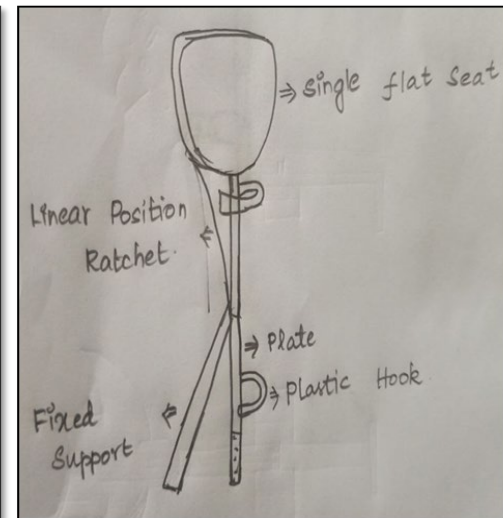

Fig. 5 Concept D

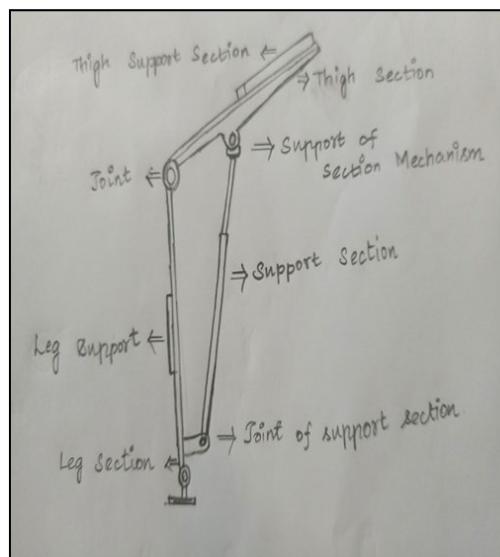

Fig. 6 Concept E



Fig. 7 Reference Design

C. Concept Screening Matrix

Concept screening is the next step in the product development process [8]. Using the screening matrix, rough first conceptions are compared to a shared reference concept as shown in figure 8 during concept screening. Numerous repetitions of the concept screening matrix may be done, yielding a novel combination of several concepts. Maintenance, customer safety, cost, convenience of handling, feasibility, and environmental friendliness are

among the chosen criteria. The existing market product is used as a reference, and pluses and minuses are calculated using the reference datum.

Thus, the steps in the concept screening matrix are

1. Prepare the selection matrix.
2. Rate the concepts.
3. Rank the concepts.
4. Combine and
5. Improve the concepts.

CONCEPT SCREENING							
S NO	SELECTION CRITERIA	A	B	C	D	E	G
							REFERENCE
1	Light weight	-	-	+	0	+	0
2	Durability	-	-	-	0	+	0
3	Reliability	-	0	-	0	+	0
4	Comfort	-	0	0	-	0	0
5	Flexibility	-	-	-	-	0	0
6	Ease of handling	0	-	+	+	0	0
7	Safety	0	+	-	0	+	0
8	Cost	-	-	+	0	0	0
9	Serviceability	+	0	0	-	0	0
	Sum of +	1	1	3	1	4	0
	Sum of -	6	5	4	3	NA	0
	Sum of 0	2	3	3	5	5	9
	NET SCORE	-5	-4	-1	-2	4	0
	RANK	5	4	2	3	1	2
	CONTINUE?					YES	YES

Fig. 8 Concept Screening Matrix

CONCEPT SCORING														
S. No.	Selection criteria	Weight (%)	A		B		C		D		E		REFERENCE	
			Rating	Weighted score	Rating	Weighted score	Rating	Weighted score	Rating	Weighted score	Rating	Weighted score	Rating	Weighted score
1	Light weight	10	2	0.2	1	0.1	3	0.3	3	0.3	4	0.4	3	0.3
2	Durability	5	2	0.1	2	0.1	2	0.1	3	0.15	4	0.2	3	0.15
3	Reliability	5	2	0.1	3	0.15	2	0.1	3	0.15	4	0.2	3	0.15
4	Comfort	20	2	0.4	3	0.6	3	0.6	2	0.4	3	0.6	3	0.6
5	Flexibility	5	2	0.1	1	0.05	1	0.05	2	0.1	3	0.15	3	0.15
6	Ease of handling	30	3	0.9	1	0.3	4	1.2	4	1.2	3	0.9	3	0.9
7	Safety	10	3	0.3	4	0.4	1	0.1	3	0.3	4	0.4	3	0.3
8	Cost	10	2	0.2	2	0.2	4	0.4	3	0.3	3	0.3	3	0.3
9	Serviceability	5	4	0.2	3	0.15	3	0.15	2	0.1	3	0.15	3	0.15
	TOTAL SCORE			2.5		2.05		3		3		3.3		3
	RANK		5		4		3		2		1			2
	CONTINUE??										YES			

Fig. 9 Concept Scoring Matrix

D. Concept Scoring Matrix

Following the concept screening matrix, need to create a concept scoring matrix [8]. When a higher resolution is needed to distinguish between competing concepts, concept scoring is applied. The team weighs the relative value of the selection criteria at this stage as shown in figure 9, focusing

on more refined comparisons for each one. The concept scores are determined by the weighted sum of the ratings.

1. Much worse than reference – 1
2. Worse than reference – 2
3. Same as reference – 3
4. Better than reference – 4

E. Finalized Design

The finalized design after performing the concept screening and concept scoring method as shown in figure 10. The individual must first put on the exoskeleton correctly. The shoes are the first to be worn. The hip area straps are then snugly secured around the user, and the shoulder and chest supporting straps are modified to fit the user’s body size, making it more comfortable to wear. After the exoskeleton has been appropriately attached to the user’s body, the user should apply mechanical pressure to the rod near the butt area. The rod receives pressure when the user’s entire body weight is applied to it.

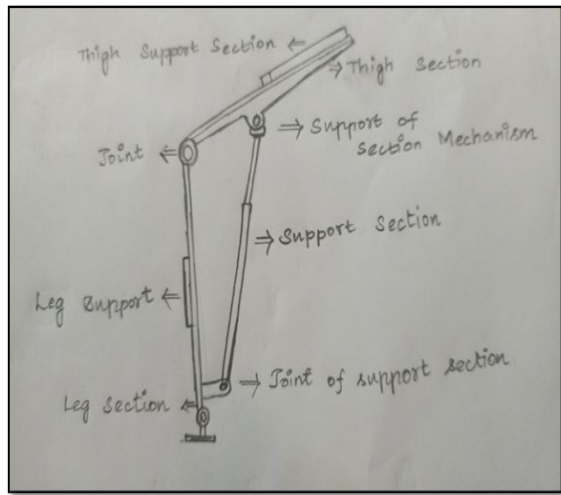

Fig. 10 Finalized design

By squeezing the hydraulic piston, the rod will pull down the thigh support stainless steel rod when it is compressed. The calf support rod will bend as a result of the compression, and the edges of the calf support rod will be balanced on the ground. Now, the entire exoskeleton will assist the user in sitting comfortably without exerting too much effort. To stand, the user must elevate his buttocks off the hip rest rod, allowing the hydraulic piston to extend the calf and thigh support to its usual position. This allows the wearer to walk up to a few meters.

F. Embodiment Design

Embodiment design is a phase of the design process in which, starting with a primary solution or concept for a technical product, the design is refined in compliance with

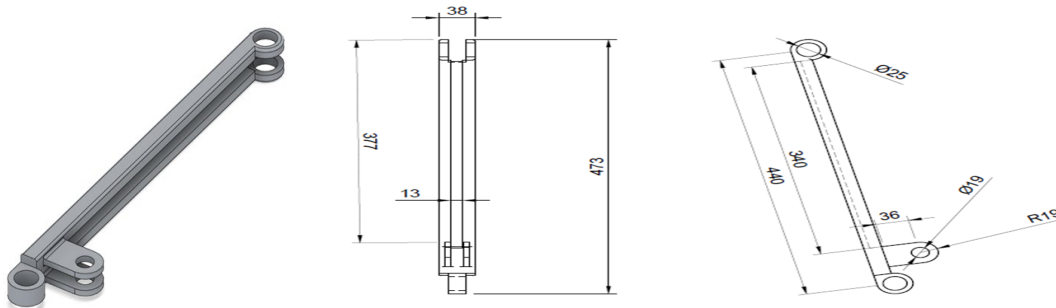

Fig. 12 Lower frame

technical and economic criteria and in light of new information, to the point when detailed design may lead to production [10].

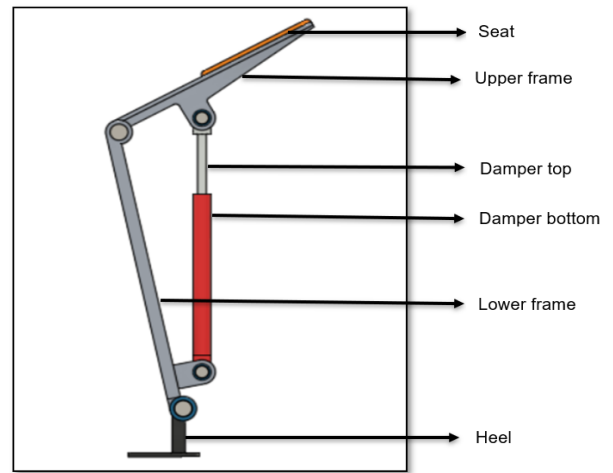

Fig. 11 CAD model of lower limb assistive exoskeleton

Individual elements were developed and built using Fusion 360 software for the chosen idea as shown in the figure 11. The dimensions of the parts were calculated using Indian Anthropometric data. AA2024 is the material given to each of the pieces. Copper is the main alloying ingredient in AA2024, which is an aluminum alloy. It’s a high-strength aluminum alloy that can be heat treated. The material was chosen for its lightweight and great load bearing capability. The material, part dimensions and mechanical motions were selected in such a way that the safety and ergonomic requirements are met.

1. Indian Anthropometric Dimensions

The overall design is made simple and which constitutes four major components and are listed below and shown in the figures 12-15.

1. Lower Frame.
2. Upper Frame.
3. Damper top.
4. Damper bottom.

The seat and heel and two other components that serve to provide comfort to the user as shown in figure 16 and 17. Based on the motion simulation from Fusion 360, it was realized that the product could serve its function.

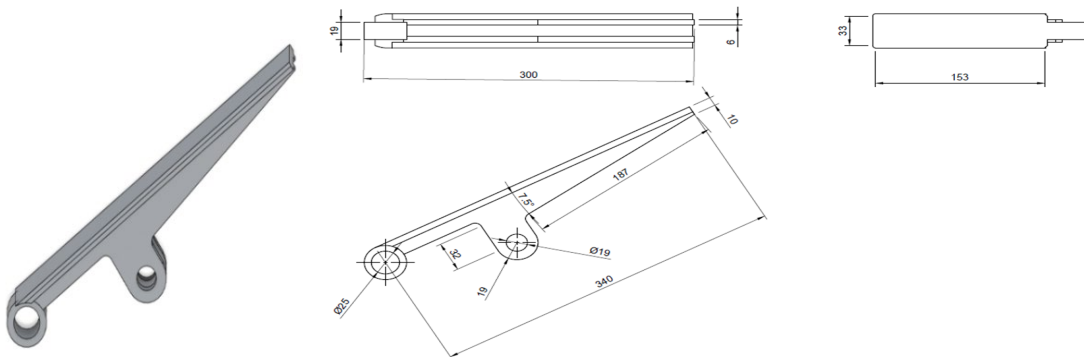

Fig. 13 Upper frame

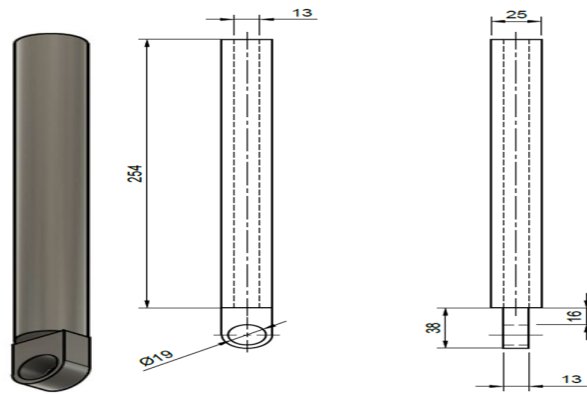

Fig. 14 Damper bottom

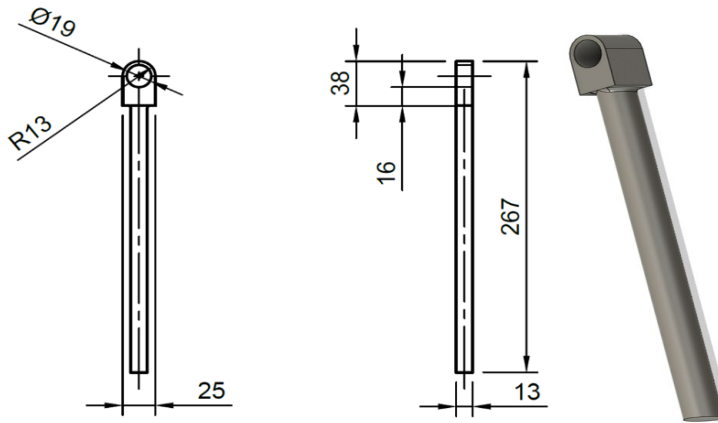

Fig. 15 Damper top

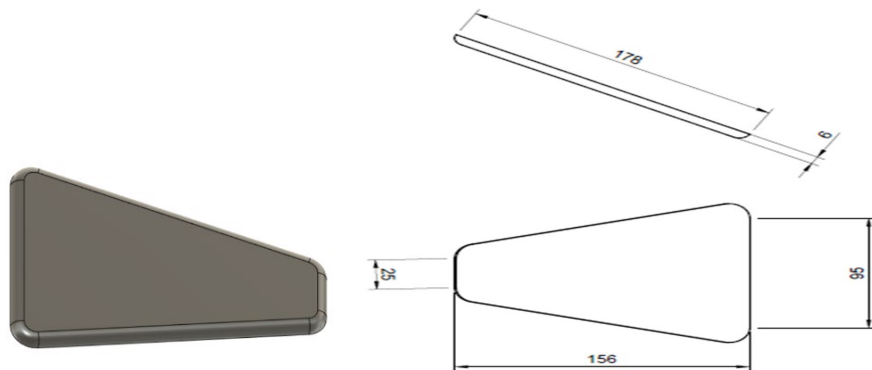

Fig. 16 Seat

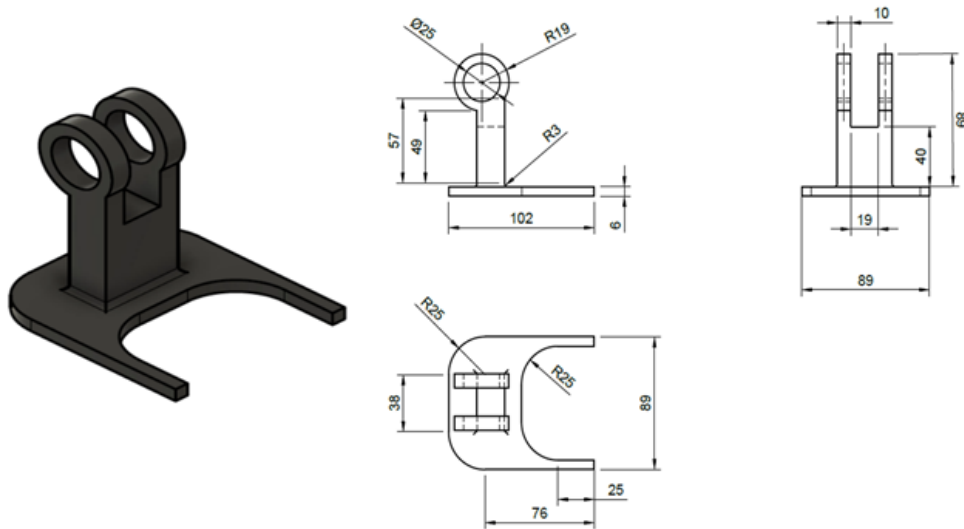

Fig. 17 Heel

G. Numerical Simulation

The Finite Element Analysis (FEA) approach is a continuous integral structure split into a finite number of units, with material characteristics, real constants, and other attributes determined for each unit at the same time. The stress and strain of all nodes and the cell have been attained, and then the circumstances of this region in general have been solved, and the solution issue has been acquired. This is an approximation solution, but as the number of units increases and the interpolation function's accuracy improves, the approximate answer approaches the genuine solution.

1. Static Structural Analysis

Static structural analysis is the process of calculating the deformation and stress of a structure under a fixed load in order to assess its strength and stiffness and guarantee that it meets the structure's security and stability requirements. Fixed loads include fixed inertial loads and loads that are roughly equal to static loads that vary slowly over time.

a. 3D Model Simplifications of Lower Limb Rehabilitation Exoskeletons

The correctness of the static analysis findings is affected by whether the finite element model is valid or not. However, establishing the suitable finite element model for complicated structures is quite challenging. As a result, before establishing a finite element analysis model of the exoskeleton, the model of the exoskeleton should be kept as simple as possible. The section that does not require analysis should be addressed with a big approximation treatment on the basis of ensuring the force.

b. Grid Partition of the Lower Limb Exoskeleton

After the three-dimensional model of the lower limb exoskeleton was simplified, the following step was to mesh

the grip model and create units. The accuracy of analysis findings and genuine credibility are directly affected by element meshing quality; hence meshing is a key phase in the finite element analysis process.

c. Creating a Contact

Contact is a highly nonlinear problem that simulates contact, friction, and relative sliding between two pieces. The creation of the suitable contact is critical for finite element analysis.

d. Define the Load

The weight of the human body (1 kN) was applied to the seat of the exoskeleton, which was the major source of load for the lower limb exoskeleton.

e. Constraints Loading

The suitable right external skeletal loading boundary restrictions guarantee the stiffness matrix is non-singular, allowing the correct solution of displacement to be obtained. The exoskeleton-imposed limits that were fixed constraints of the lower limb exoskeleton. The exoskeleton fixed constraint was the same as the human lower limb's contact area between the feet and the ground.

f. Results for Static Structural Analysis

Stress diagrams of the lower limb exoskeletons were created once the applied load, restrictions, and analysis were completed, as illustrated in figure 18 and 19. The maximum stress is 51.2 MPa, and the stress distribution suggests that the design is safe.

According to the deformation study, the largest distortion occurs at the seat, with a maximum deformation of 0.1054 mm. It's a reasonable limit, and the design may be deemed safe. It is possible to infer that the design is safe based on

the static structural analysis. The design had a larger safety factor; thus, topology optimization was used to minimize it and obtain an ideal level.

2. RULA Analysis

The RULA tool is intended to detect ergonomic risk factors linked to upper-limb musculoskeletal diseases (MSDs), which include injuries or discomfort in joints, nerves, muscles, ligaments, and tendons. The RULA tool assesses the level of risk that employees face as a result of their frequent exposure to postures and muscular activity that have been linked to strain injuries. This examination necessitates the evaluation of scores ranging from one to seven, with a lower score indicating no action necessary and

a higher score indicating quick action. PTC Creo 6.0 was used to perform the RULA analysis as shown in figure 20. The design received an RULA result score of 3, indicating that it is safe, but that it might be improved for better ergonomic performance.

Based on the analysis results, the following conclusions are made

1. The maximum stress and deformation in the design for the applied load is acceptable and the design is safer.
2. The shape optimization of the links can further reduce the overall weight of the product.
3. The RULA analysis indicates that the current design is safe but there is scope for improvement.

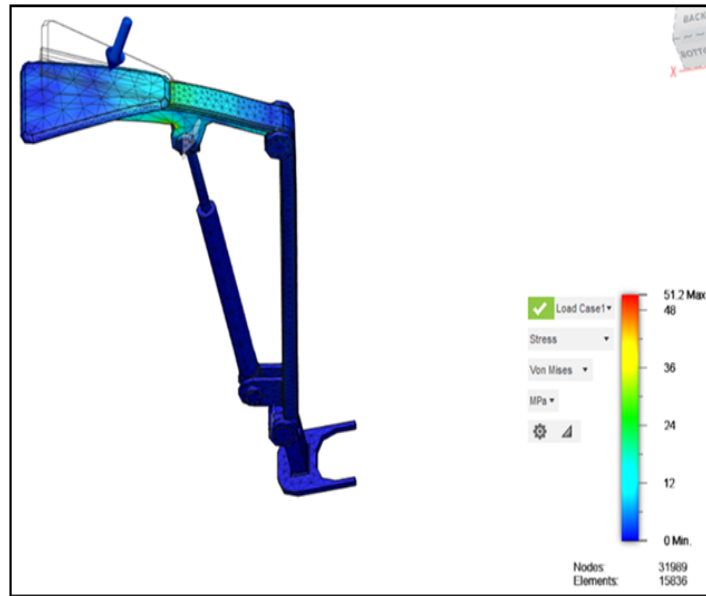

Fig. 18 Stress analysis

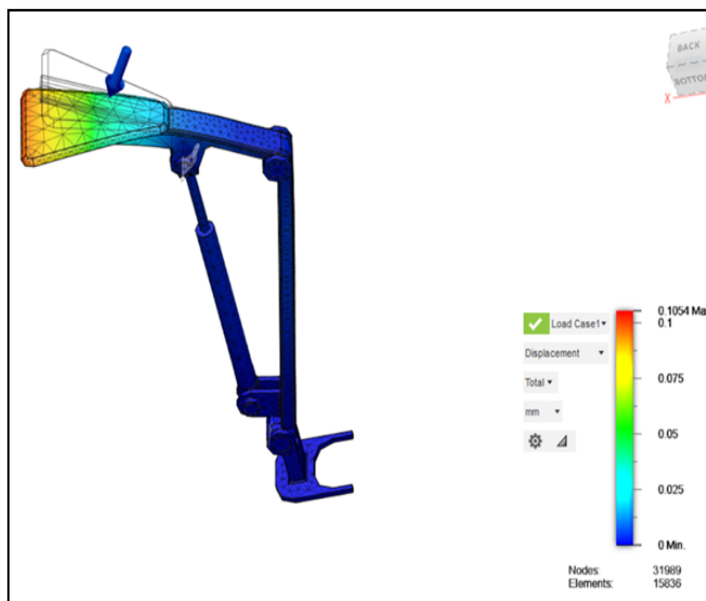

Fig. 19 Deformation analysis

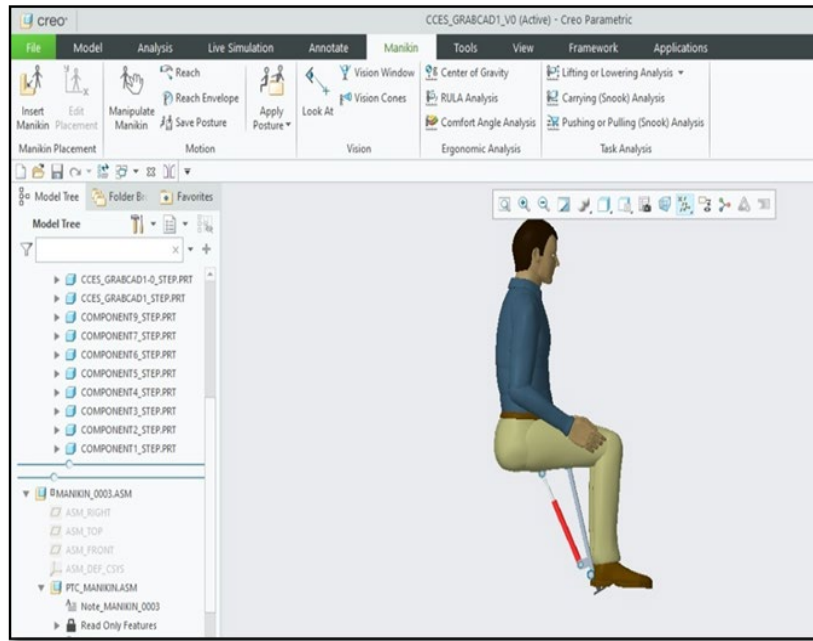

Fig. 20 RULA analysis

H. Cost Estimation

Cost is the most important factor for any product. For the prototype, a cost estimation table was proposed as shown in table 3.3. Wood and PVC Pipe were selected as the

prototype materials and an attempt was made to realize the prototype. With the selected materials, the overall cost of the prototype is estimated as Rs.525. However, this prototype could only be a structural model of the product.

S. No.	Item of Expenditure	Cost (in ₹)
1	Direct Material Cost Per Component	
	Lower frame - Wood <input type="checkbox"/> 2*2*30 cm	Rs. 95 /sq. ft.
	Upper frame - Wood <input type="checkbox"/> 2*2*17 cm	Rs. 95 / sq. ft.
	Seat - Thermocol 5*8*3 cm	Rs. 10
	Damper bottom - PVC <input type="checkbox"/> OD-1.5 cm, ID-1 cm, Length-12 cm	Rs. 70 / m
	Damper top - PVC <input type="checkbox"/> OD-0.9 cm, Length-10 cm	Rs. 70 / m
	Heel - Wood	Rs. 95 / sq. ft.
	Adhesive	Rs. 90
2	Total Cost of the Product developed	Rs. 525

Fig. 21 Cost estimation for exoskeleton

I. Advantages and Challenges of Exoskeleton

The portability of this assistive exoskeleton is its key benefit. It may be readily transported by storing it in a bag. The user may even move their legs to walk to a distant exoskeleton. So that the user does not have to detach the exoskeleton every time he moves.

Because certain tasks do not prompt the applicant to be sitting, but if they're against a lengthy amount of time, it may create a muscular or leg cramp, and that's where an assisted exoskeleton may aid.

There are certain difficulties in using this assistive exoskeleton. The individual wearing the exoskeleton should exert physical force. Because this model was made from scrap, there are too many straps used for balance; however, if cost is not an issue, simpler and lighter straps may be utilized. It doesn't offer the same measure of relief as a regular chair. It helps you to sit and walk securely while allowing you to concentrate on your work. Due to the absence of back support, positions such as kneeling, squatting, or poses beyond 90 degrees of angle might cause the consumer to lose balance. To make efficient use of this chair-less chair, then one must know how to balance it.

IV. FUTURE SCOPE

Because of the material's accessibility, the choice of material for this work was limited. In the future, the composite material might be utilized to reduce the structure's weight while increasing its strength. Different locking systems may be used to make the chair work better and more smoothly. This chair is likely to reduce lower-body weariness, but it requires further adjustment to achieve its full potential. It can be adjusted to assist those who are crippled (for example, those who are unable to walk due to a lack of legs).

V. CONCLUSION

The model would be able to withstand a weight of about 100kg. The gross weight of the mechanism for both legs is estimated to be around 3 kg, and the prototype meets the lightweight criteria when compared to typical chairs. It lowers the risk of musculoskeletal disorders and makes it simple to operate with the equipment as needed by the customer. The design must be implemented and tested in a real-world setting, and the efficacy in everyday circumstances must be assessed. The product's intended outcome shows that the flexible wearable chair meets balance and stability standards and can reduce tiredness while working. It improves worker performance while reducing the negative health effects faced by workers in a certain industry.

REFERENCES

- [1] Keith Gunara, *et al.*, *Wearable posture assisting device (ETH Zurich)*, patent WO 2015028373 A1.
- [2] Alexander Egoyan and Karlo Moistsrapishvili, "Equilibrium and Stability of the Upright Human Body," *The General Science Journal*, pp. 2-4, 2013, ISSN 1916-5382.
- [3] Assessment of User Needs in the Design of a Wearable Robot for Neurorehabilitation, presented at the DLSU Research Congress 2017 De La Salle University, Manila, Philippines June 20 to 22, 2017.
- [4] N. Costa, *et al.*, "Joint motion control of a powered lower limb orthosis for rehabilitation," *International Journal of Automation and Computing*, Vol. 3, No. 3, pp. 271-281, 2006.
- [5] Cyril Varghese, "Design and fabrication of exoskeleton based on hydraulic support", *International journal of advanced research*, Vol. 4, No. 3, pp. 22-28, 2016.
- [6] Ashutosh Bijalwan, *et al.*, "Design and Structural Analysis of Flexible Wearable Chair Using Finite Element Method," *Open Journal of Applied Sciences*, Vol. 6, pp. 465-477, 2016.
- [7] Aydin Tozeren, "Human body dynamics: Classical mechanics and Human movement," *Springer Science & Business Media*, 1999.
- [8] H. Zurina, *et al.*, "The design and development of the lower body Exoskeleton," *2nd Integrated design project conference (IDPC)*, 2015.
- [9] J. Racine, *et al.*, "Control of a lower extremity exoskeleton for human performance amplification," 2003.
- [10] J. R. Steger, "A design and control methodology for human exoskeletons," *ProQuest*, 2006.
- [11] Aditya Bhalerao *et al.*, "Pneu Portable Chair," *International Journal of Scientific Research*, Vol. 5, March 2016.
- [12] D. R. Bonner, *Wearable Chair*, U.S. Patent 4,138,156, Filed September 6, 1977, and Issued February 6, 1979.
- [13] S. T. McCaw *et al.*, "Biomechanical implications of mild leg length inequality," *British journal of sports medicine*, Vol. 25, No. 1, pp. 10-13, 1991.
- [14] P. Davidovits, *Physics in Biology and Medicine*, 3rd Edition, Elsevier, USA, 2-3. 2008.
- [15] Robert Peter Matthew *et al.*, "Introduction and initial exploration of an Active/Passive Exoskeleton framework for portable assistance," *IEEE/RSJ International Conference on Intelligent Robots and Systems (IROS)*, 2015.