

# Development and Travel Time Analysis of Automated Storage and Retrieval System

Anuradha S. Parab<sup>1</sup> and P. N. Gore<sup>2</sup>

<sup>1</sup>P.G. Student, <sup>2</sup>Associate Professor

Department of Mechanical Engineering, DKTE's Textile and Engineering Institute, Ichalkaranji, Maharashtra, India.

E-mail: [apanuradhaparab@gmail.com](mailto:apanuradhaparab@gmail.com)

(Received 17 May 2020; Revised 8 June 2020; Accepted 24 July 2020; Available online 30 July 2020)

**Abstract** - Automated storage and retrieval system (AS/RS) is major automated storage method mainly used in warehouse and distribution centers. Objective of the study is to analyze expected travel time while performing storage/ travel request for randomized storage allocation and return to input-output dwell point policy. Single and Dual command cycle time expressions are verified through mathematical calculations and experimental observations. AS/RS model is prototyped with the help of Arduino Uno microcontroller board used as programmable controller system. Android interfacing makes system easy to access and control. Physical prototyping of AS/RS ensures better knowledge gain related to hardware, software and communication interfacing module.

**Keywords:** Automated Storage and Retrieval System, Arduino Uno Board, Expected travel time.

## I. INTRODUCTION

A material storage system allows use of storage space over period and access to the material when it is needed. Automated storage methods are preferred to overcome inefficiencies of human errors. Hence, an automated storage/retrieval system can be defined as a storage system under which a defined degree of automation is to be implemented to perform storage and retrieval operations [4]. Primary objective of automated storage system is to store or deliver right material to desired station at right time with minimum cost. Material handling process is carried through machine whereas human aid is needed to operate and control machine operations.

General AS/RS consists of storage racks, storage/retrieval machine(S/R machine), Input-output stations (I/O station). Pick up and deposit operations performed at I/O station by manually or performed by machine such as Pick and Place Robot, Conveyor, etc. Location of each unit load is predefined over rack. Unit load is of standard size to ensure smooth handling of load by S/R machine. A Computer control system and programmable controllers are used to determine the required location and guide the S/R machine to its destination.

AS/RS is used over main application areas such as unit load storage and handling, order picking and work-in-process storage system as it offers cost effective utilization of time, space and equipment with protection to product item.

AS/RS makes material management faster and more reliable with the least failure which increases accuracy and throughput capabilities. Standard and modular system ensures easy and faster maintenance. AS/RS enables real time information management through automatic identification of items and record keeping.

## II. LITERATURE SUMMARY

While designing AS/RS, Unit load is preferred over other types of AS/RS. While analyzing performance of AS/RS, key factor is travel time which is necessary to minimize for expected travel run. Analytical expressions and Computer simulations help to compare different types of AS/RS with dwell point policies and storage allocation policy.

Sarker and Babu [2] have presented critical review and a comparative study of design aspects of automated storage/retrieval systems with special emphasis on travel time models along with the throughput rate, sequencing rules, order batching algorithms and dwell point strategies. Yavuz Bozer *et al.* [12] have derived mathematical expressions of travel time model for unit load, continuous rack under various dwell point policies for both single and dual command cycles. M. Aslam *et al.* [3] implemented travel time model by Yavuz Bozer for designed AS/RS and validated with MATLAB simulation. S. G. Koh *et al.* [9] adopted randomized storage assignment rule to obtain the travel time of the S/R machine analytically for single and dual command policies under stay dwell point strategy. Zaki Sari *et al.* [13] worked on travel time mathematical expressions for flow rack system based on continuous approach. Results are then evaluated for throughput of system to set standards and compared with exact models based on discrete approach. Tone Lerher *et al.* [10] proposed travel time model for multi-aisle AS/RS with single S/R machine to verify efficiency of analytical and simulation model. Amine Hakim Guezzen *et al.* [1] modeled continuous and discrete mathematical travel time expression for Mobile rack AS/RS. M. R. Vasili *et al.* [6] have developed continuous travel time model for new AS/RS configuration where two I/O stations are used per aisle which enhance performance of system. For above system vertical platforms returns to I/O station and horizontal platform returns to middle location of row after

completion of operation. Mohammadreza Vasili *et al.* [7] studied characteristic of Mini-Load AS/RS through Heuristic algorithms are used for load shuffling and travel time analysis for storage platform. Mohammadreza Vasili *et al.* [5] compared mathematical model of Travel time Analysis of split platform AS/RS under stay idle, return to I/O station, return to middle dwell point locations for load above 20 Ton at higher speeds. Ya-Hong Hu *et al.* [11] derived and validated travel time model for split platform AS/RS for heavy load under stay idle dwell point policy along with guidelines for optimal design of a rectangular-in-time AS/RS rack with the new S/R mechanism. Po-Hsun Kuo *et al.* (2007) proposed computational travel time model for autonomous vehicle technology for random storage and stay dwell point policy.

### III. AS/RS DEVELOPMENT

#### A. Construction of AS/RS

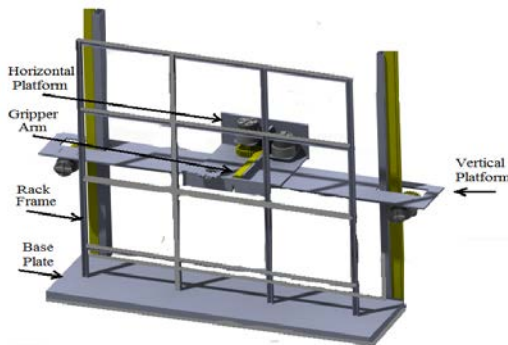

Fig.1 3-D Model of AS/RS Assembly

Present AS/RS system is prototyped with minimum cost to study the travel time under different dwell point locations. Entire structure is mounted on wooden floor. Rack is framed with 9 cells for storage locations. Storage and retrieval machine consist of horizontal platform which can slide over vertical pillars. Carriage is provided over horizontal platform that travels along length of platform. Picker arm is fitted over carriage to pick the item from rack. The horizontal and vertical movements are possible through rack and pinion powered through dc gear motor. Pick and place motion of gripper arm is controlled by means of servo motor.

#### B. Control System

Control system is an information processing unit consists of computer hardware and software system. This control system gathers various commands and action plans in the form of digital code and operate according to program code provided by user. It supervises and conducts the inputs as well as outputs according to the program code. Thus, Control system does real time information processing and decision-making to manage the input and outputs. To provide cost effective solution to control

system Arduino Uno board is used. Android application is developed to interface man and machine through Bluetooth module. Arduino is an open source prototyping platform that uses easy to use hardware and software which is free to use and modify any circuit. Arduino Uno employs microcontroller board having software called Arduino IDE (Integrated Development Environment), which is used to write Arduino programming language and upload the computer code to the physical board. The Arduino software-IDE is programmable software that uploads code to microcontroller. It contains a text-editor and compiler that translates the Arduino program into a more complicated binary hex file that can be uploaded directly to the micro-controller. Arduino board reads the input instructions provided in programming language and produces output signal for the hardware interfaced with the microcontroller. So the Arduino boards are able to read, process and produce analog as well as digital signals. Following are the input, outputs to the Arduino Uno microcontroller.

TABLE I LIST OF COMPONENTS

Component	Specification	Quantity
Arduino Uno Board	ATmega328 Microcontroller Operating Voltage: 5V	1
<b>List of Inputs</b>		
HC-05 Bluetooth Module	3.3V DC	1
IR Sensor	3.6 to 5V DC	2
<b>List of Outputs</b>		
DC Gear Motor (Vertical and Horizontal Platform)	12V DC, 60rpm	3
DC Gear Motor (Gripper Assembly)	12V DC, 10rpm	1
DC Servo Motor (Gripper Arm)	5V DC	1
LM-298 Driver	5-35V DC	3

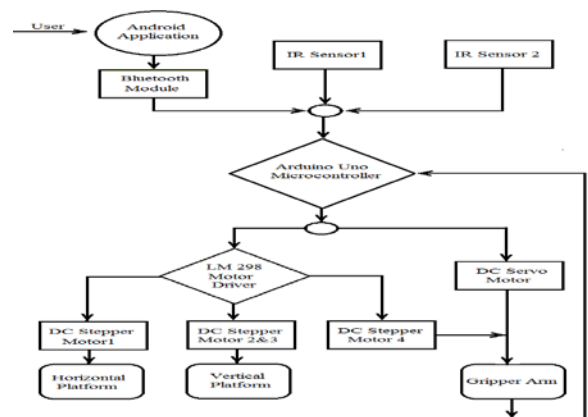

Fig.2 Flow chart of Control System

#### IV. DESIGN OF AS/RS

##### A. Physical Design of System

Physical system defines configuration of system along with dimensions. Present prototyped storage/retrieval machine can handle 200gm of weight. System under study can be configured as:

1. Single Aisle, rectangular, one sided rack, pick face is considered.
2. Single S/R machine is used.
3. Input-Output station is considered at location 1, lower right corner in the rack.
4. Unit load is carried over pallet which is used as base plate.
5. Each space contains single unit load only.
6. All storage locations as well as unit loads are identical in shape and size.
7. S/R machine operates on either Single or Dual command basis.
8. S/R machine has independent drives for vertical and horizontal travel movement.
9. The specification of the S/R machine such as maximum velocities in horizontal and vertical directions as well as the length and the height of the S/R machine are known.
10. Dwell point Location: Location1 in the rack (Row1,Column1).
11. Dwell point policy: Strategy A where S/R machine returns to Location 1 in the rack after completion of each cycle.

##### B. Sizing of Unit Load and Storage Rack

Rack and Unit load of automated storage and retrieval system under study is considered in two dimensions only- Length and Height whereas Depth of Rack, Unit load is neglected

###### 1.Storage Capacity of Aisle

It is defined as total volumetric space or total number of storage spaces available for product to be stored.

Let  $n_x$  –Number of storage cells across length  
 $n_x=3$

$n_y$  –Number of storage cells across Height  
 $n_y=3$

If loads are arranged on a single side of rack,  
 Capacity per aisle =  $n_x \cdot n_y=3 \times 3=9$

###### 2. Sizing of Storage Cell

Let  $x$  – Length of unit load

$y$  – Height of unit load

$z$ – Depth of unit load

$\therefore$  Total Length, Height, Depth of Unit Load is,

$$L=(x+a)$$

$$H=(y+b)$$

$$D=(z+c)$$

Where  $a$ ,  $b$ , and  $c$  are allowances designed for each storage compartment to provide clearance for the unit load and to account for the size of the supporting beams in the rack structure.

$$L = (x + a) = (120 + 2 \times 15) = 150\text{mm}$$

$$H=(y+b)=(100+20+30)=150\text{ mm}$$

$$D=(z+c) = \text{Not decided}$$

##### 3..Pallet Dimensions

Length of Pallet = 130mm

Height of Pallet = 30mm

Depth of Pallet = Not decided.

##### 4.Rack Dimensions

Total Length of Rack Frame:

$$L_{\text{Rack}} = 3 \times \text{Length of unit load} + 3 \times \text{Thickness of wall} \\ = 3 \times 150\text{mm} + 3 \times 10\text{mm}$$

$$\therefore L_{\text{Rack}} = 480\text{mm}$$

Total Height of Rack Frame:

$$H_{\text{Rack}} = 3 \times \text{Length of unit load} + 3 \times \text{Thickness of wall} + \\ \text{Height above base plate} \\ = 3 \times 150 + 3 \times 10\text{mm} + 100\text{mm}$$

$$\therefore H_{\text{Rack}} = 580\text{mm}$$

Total Depth of Rack: Not Decided.

The final arrangement of Unit load, Pallet and Cell in the rack will be:

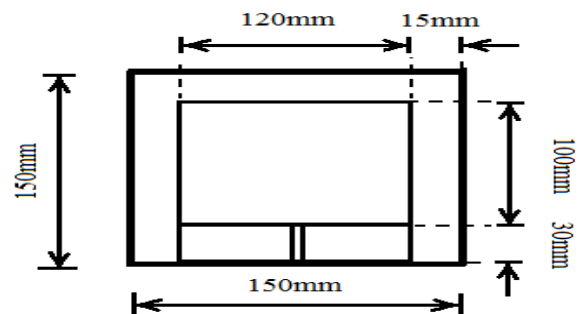

Fig.3 Unit Load Arrangement in Rack

##### C. Selection of Control Policies of AS/RS

Actions performed by AS/RS are determined by control policies of AS/RS. Hence, it is collective set of instructions to determine operation of AS/RS. Following control policies are selected while studying system:

1. Random storage allocation policy selected so that any space can be selected for storage and each space have equal probability of getting selected.
2. S/R machine operates on single and dual command cycle to study expected cycle time. Single command

operation involves single storage or retrieval operation per request whereas Dual command cycle involves storage operation followed by retrieval operation per request.

3. Lower left corner of rack is selected as dwell point location as well as input-output station.
4. To evaluate expected cycle time for single and dual command cycle return to input-output station policy is selected.
5. All storage and retrieval transactions are performed on first come first serve order picking policy.
6. No interleaving or stop is allowed middle in the operation.

**V. ANALYSIS OF AS/RS**

Analysis of AS/RS involves travel time calculation until completion of operation depending upon type of command cycle and dwell point policy. For single command storage or retrieval cycle time determines travel time when machine picks up a load travels to the storage/retrieval location, deposits the load and travel back to the input – output station. In case of Dual command cycle travel time is determined when machine picks up the load and travel to the storage location to unload the item. Then, the machine moves towards retrieval location to recover the load and travels back to the Input-output station to deposit the load. Assumptions made while evaluating travel time equation are as follows:

**A. Assumptions**

1. Randomized storage allocation policy.
2. Random order picking policy.
3. Dwell point Location and Input-Output station :Location 1 in the rack (Row1,Column1)
4. Dwell point policy: Strategy A where S/R machine returns toInput-Output station in the rack after completion of each cycle.
5. Acceleration and deceleration effects of electric drives are neglected.
6. Velocity is constant throughout in each direction.
7. Travel time is measure of maximum of isolated horizontal and vertical travel time.
8. Velocity of each platform is constant throughout in each direction.
9. No interleaving or stop is allowed middle in the operation.
10. Pick up and Deposit time is irrespective of rack shape and velocities of S/R machine. So, Average pick up and deposit time is added at the last to the equation of Expected cycle time.

While performing actual trials at S/R machine following parameters are observed during actual operation of S/R machine.

- I. Velocity of Horizontal Platform: 2.6cm/s
- II. Velocity of Vertical Platform: 2.6 cm/s

III. Average pick up and deposit time: 13sec

**B. Determination of Expected time for Single Command Cycle**

According to Bozer and White [12], Expected Single Command cycle time under Dwell point strategy where S/R machine returns to Input–Output Station located at bottom right corner is given by,

$$\therefore T(SC) = T \cdot \left( \frac{b^2}{3} + 1 \right) + 2 \cdot T_{PD}$$

Where T- Time normalization factor = Max ( T<sub>H</sub> , T<sub>V</sub> )

b- Shape factor = Min (  $\frac{T_H}{T}$  ,  $\frac{T_V}{T}$  )

- T<sub>PD</sub>- Load pick-up and deposit time.
- T<sub>H</sub> – Time required traveling up to L.
- T<sub>V</sub> – Time required travelling up to H.

TABLE II EXPECTED CYCLE TIME FOR SINGLE COMMAND CYCLE

Location	Row	Column	Theoretical Time	Actual Time	% Deviation
1	1	1	26.00	26.03	0.12
2	1	2	38.31	38.92	1.60
3	1	3	50.62	50.84	0.44
4	2	1	38.31	59.46	55.22
5	2	2	42.41	47.23	11.36
6	2	3	52.67	59.76	13.47
7	3	1	50.62	68.61	35.55
8	3	2	52.67	56.09	6.50
9	3	3	58.82	68.28	16.08

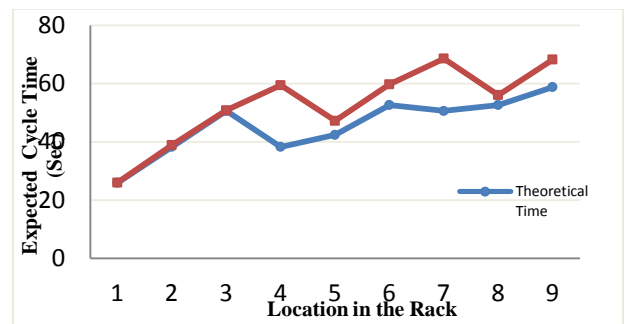

Fig.4 Comparison between Theoretical and Actual Cycle Time for Single Command Cycle

**C. Determination of Expected time for Dual Command Cycle**

According to Bozer and White [12],

Expected Dual Command cycle time under dwell point strategy A (S/R machine returns to Input-Output Station located at bottom right corner) is given by,

$$T(DC)=E(SC)+E(TB)+4 \cdot T_{PD}$$

$$\therefore T(DC) = T \cdot \left( \frac{4}{3} + \frac{1}{2} \cdot b^2 - \frac{1}{30} \cdot b^3 \right) + 4 \cdot T_{PD}$$

Where

E(SC) – Expected time for single command cycle. E(TB)- Expected time for travel between storage and retrieval locations.

T- Time normalization factor = Max ( T<sub>H</sub> , T<sub>V</sub> )

b- Shape factor = Min (  $\frac{T_H}{T}$  ,  $\frac{T_V}{T}$  )

T<sub>PD</sub> - Load pick-up and deposit time.

T<sub>H</sub> – Time required traveling up to L.

T<sub>V</sub> – Time required travelling up to H.

TABLE III EXPECTED CYCLE TIME FOR DUAL COMMAND CYCLE

Reading Number	Location		Cycle Time		% Deviation
	Storage	Retrieval	Theoretical Cycle Time	Actual Cycle Time	
1	1	5	74.15	76.24	2.81
2	1	9	96.31	100.04	3.88
3	3	5	87.79	88.61	0.93
4	3	8	96.31	100.28	4.12
5	4	6	91.40	100.02	9.43
6	5	1	74.15	76.84	3.62
7	5	9	96.31	100.56	4.42
8	6	1	87.79	88.89	1.25
9	8	2	87.79	88.02	0.26
10	9	5	96.31	100.27	4.11

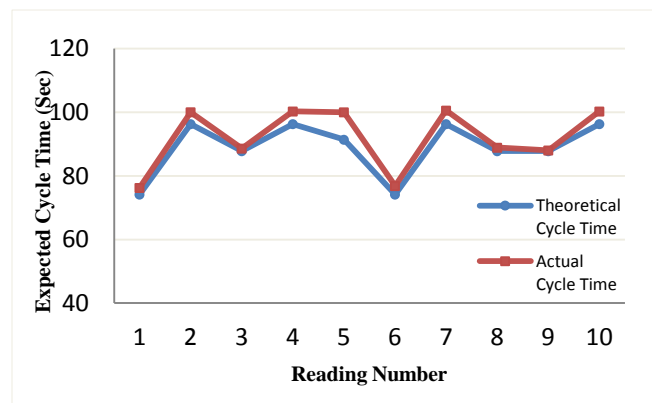

Fig.5 Comparison between Theoretical and Actual Cycle Time for Dual Command Cycle

Table II& III and Figure 4&5 shows comparison between theoretical and actual cycle time for Single and Dual command cycle along with % deviation between

theoretical and actual cycle. There is a deviation in actual time as compared to Theoretical time as it is assumed that S/R machine runs simultaneously in horizontal and vertical direction whereas in actual set up horizontal platform moves first and then vertical platform travel which adds travel time. Also, Also while entire travel run velocity of S/R machine should be kept constant but it may not be as while moving downward vertical platform moves faster due to self-weight. The effect of acceleration and deceleration also neglected while developing mathematical model whereas it affects actual travel time.

The pick points in the % deviation curve shows the location where actual travel time is more than theoretical time as path of AS/RS model is defined while Arduino programming as it will always proceed through second column first while moving towards location in the row 2 and 3 instead of directly passing through first or third column. Hence, it adds up with unnecessary travel distance through column 2 which increases travel run and travel time resulting in a greater deviation.

## VI. CONCLUSION

For present study Arduino based AS/RS prototype has been developed and analyzed for expected travel time. For AS/RS system under study, theoretical and actual travel time is compared under randomized storage and return to Input-output dwells point policy. Dual command cycle has less deviation in theoretical and travel time than single command cycle, So Dual command cycle should be preferred over single command cycle to raise throughput of system. Result of experiments shows that it is possible to minimize actual travel time by overcoming the assumptions. Also, use of Arduino Uno as control system makes AS/RS prototyping cost effective. Android application interface through Bluetooth module makes system smarter and easily accessible.

## REFERENCES

- [1] Amine Hakim Guezzen, Zaki Sari, Pierre Catagna and Olivier Cardin, "Travel Time Modeling and Simulation of Mobile Racks Automated Storage /Retrieval System", *IACSIT International Journal of Engineering and Technology*, Vol.5, No.3, June 2013.
- [2] Bhaba R. Sarker and P. Sobhan Babu, "Travel Time Models in Automated Storage/ Retrieval Systems: A Critical Review", *International Journal of Production Economics*, Vol.40, pp. 173-184, 1995.
- [3] M. Aslam, Farrukh, A. R. Gardezi and Nasir Hayat, "Design, Development and Analysis of Automated Storage and Retrieval System with Single and Dual Command Dispatching using MATLAB", *World Academy of Science, Engineering and Technology*, 36, 2009.
- [4] M. P. Groover, *Automation, Production Systems and CIM*, 3rd Edition, Prentiss Hall, pp. 328-356, 2002.
- [5] M. R. Vasili, S.H. Tang ,S.M. Homayouni and N. Ismail, "Comparison of Different Dwell Point Policies for Split Platform Automated Storage and Retrieval System", *International Journal of Engineering and Technology*, Vol.3, No.1, pp.91-106,2006.
- [6] Mohammadreza Vasili, Mehadi Vasili, Reza Raminfar and Pooria Matorian, "A Closed Form Model for Travel Time of Split Platform Automated Storage and Retrieval System Equipped with Two Input/



- Output Stations”, *9th International Conference of Modelling, Optimization and Simulation*, June 6-8, 2012.
- [7] Mohammadreza Vasili and Seyed Mahdi Homayouni, “Load Shuffling and Travel Time Analysis of Miniload Automated Storage and Retrieval System with an Open Rack Structure”, *Proceedings of the 41st International Conference on Computers & Industrial Engineering*, pp.900-905, Jan.2011.
- [8] Po-Hsun Kuo, Ananth Krishnamurthy and Charles J. Malmborg, “Models for Unit Load Storage and Retrieval Systems Using Autonomous Vehicle Technology and Resource Conserving Storage and Dwell Point Policies”, *Applied Mathematical Modeling*, Vol. 31, pp. 2332–2346, 2007.
- [9] S.G. Koh, B.S. Kim and B.N. Kim, “Travel Time Model for the Warehousing System with A Tower Crane S/R Machine”, *Computers & Industrial Engineering*, Vol.43, pp.495-507, 2002.
- [10] Tone Lerher, Matjaz Sram, Janez Kramberger, Iztok Potrc, Matej Borovinsek and Blaz Zmazek, “Analytical Travel Time Models for Multi Aisle Automated Storage and Retrieval Systems”, *International Journal Advanced Manufacturing Technology*, Vol.30, pp. 340–356, 2006.
- [11] Ya-Hong Hu, Shell Ying Huang, Chuanyu Chen, Wen-Jing Hsu, Ah Cheong Toh, Chee Kit Loh and Tiancheng Song, “Travel Time Analysis of A New Automated Storage and Retrieval System”, *Computers & Operations Research*, Vol.32, pp.1515–1544, 2005.
- [12] Yavuz A. Bozer and John A. White, “Travel-Time Models for Automated Storage/ Retrieval Systems”, *IIE Transactions*, Vol.16, No.4, pp.329-338, 1984.
- [13] Zaki Sari, Can Saygin and Noureddine Ghouali, “Travel-Time Models for Flow-Rack Automated Storage and Retrieval Systems”, *International Journal of Advanced Manufacturing Technology*, 2005.