

Development of Arduino UNO Based Automated Storage and Retrieval System

Anuradha S. Parab¹ and P. N. Gore²

¹P.G. Student, ²Associate Professor, Dept. of Mechanical Engineering,
DKTE's Textile and Engineering Institute, Ichalkaranji, Maharashtra, India
E-mail - apanuradhaparab@gmail.com

(Received 7 January 2020; Revised 30 January 2020; Accepted 21 February 2020; Available online 26 February 2020)

Abstract - Automated storage and retrieval system (AS/RS) is prototyped to take account of effect of various dwell point strategies and locations of input-output station on expected travel time and throughput of system. The effect of shape function on expected cycle time and throughput of system. Arduino UNO microcontroller is used to control and operate storage and retrieval functions. Arduino UNO software provides complete package of flexible programming platform for control operation of input output devices. Android interfacing to control system provides smarter and easily accessible human control panel.

Keywords: Automated storage and retrieval system, Arduino UNO microcontroller, Expected cycle time Dwell point strategy.

I. INTRODUCTION

Automated storage and retrieval system (AS/RS) are conventionally used in warehouse, logistics and distribution centers to store/retrieve raw material, work-in-process, and finished goods. According to Material Handling Institute of America, AS/RS is a combination of equipment and controls handling storage/retrieval request with speed and accuracy under defined degree of automation.

Typical AS/RS structure composed of series of storage racks along with material handling system called storage/retrieval machine (S/R machine). Storage structure is steel framework holding unit loads containing with sufficient strength and rigidity. S/R machine is capable of handling storage module while having a linear motion in a horizontal and vertical direction. To have desired motion of S/R machine drive systems are provided for each direction. Unit load is standard module containing item to be stored. Standard module size is provided to fit in the storage cell of rack. Unit loads to be stored/retrieved are loaded-unloaded at input-output station. Programmable control system is provided to operate S/R machine along with manual control.

Supervisory control of AS/RS ensures automatic identification and record keeping instantaneous in real time. Faster response time, protection against damage to product, the ease of maintenance, lower lifecycle cost with high return on investments are major advantages of AS/RS. Routine maintenance and occasional repair need additional

downtime, but it is still cheaper than labor cost. System is less flexible to highly variable operations and demands excessive training and technical skill to handle safely. This automated storage facility needs huge initial investment and knowledge of system structure, storage space layout and operation control strategies. Hence, objective of the study is to evaluate minimum expected travel time for various dwell point strategies and locations of input-output station of storage/retrieval machine.

II. LITERATURE SUMMARY

Various study approaches have presented in the literature analyzing expected travel time and throughput of the system. Yavuz Bozer *et al.* [8] have presented mathematical model expressing expected travel time for unit load AS/RS under various dwell point strategy. Ya-Hong Hu *et al.* [7] derived mathematical model for split-platform AS/RS carrying heavy loads under stay dwell point strategy. Mohammadreza Vasili *et al.* [1] compared mathematical travel time model under stay idle, return to I/O station, return to middle dwell point locations which outperforms for stay dwell point strategy. M. R. Vasili *et al.* [2] suggested continuous travel time expression for split platform AS/RS for two input-output stations. Mohammadreza Vasili *et al.* [3] simulated heuristic algorithm for load shuffling and expected travel time to reduce average travel time. Tone Lerher *et al.* [5] worked on analytical travel time model for multi-aisle AS/RS with single S/R machine and simulated mathematical model to verify effectiveness of model. Zaki Sari *et al.* [10] carried out optimization of floor space for minimization of travel time with return to input-output station and return to mid-point location of rack dwell point strategies. Influence of shape factor on travel is also studied to compare the performance of system. Po-Hsun Kuo *et al.* [4] compared travel time model of Autonomous vehicle technology with AS/RS working under stay idle dwell point strategy. Yaghoob Khojasteh Ghamari *et al.* [6] proposed algorithm for order picking in end-of-aisle system to minimize travel run for stay dwell point strategy.

III. AS/RS DEVELOPMENT

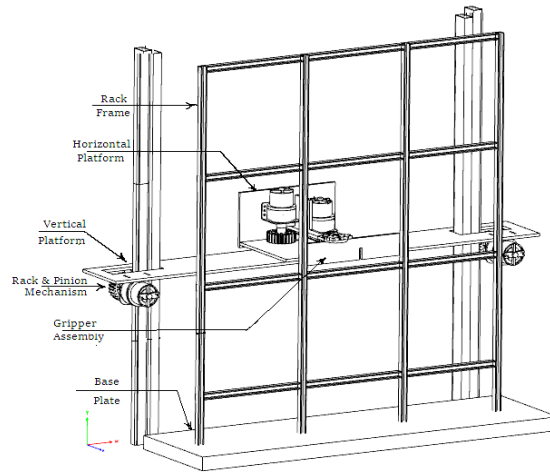

Fig.1 3-DModel of as/rs Assembly

A. Configuration of System

AS/RS under study is prototyped to study the minimum expected travel time for various dwell point strategies and locations of input-output station of storage/retrieval machine. Entire structure is fixed on wooden floor. 2-Dimensional aluminum rack frame and S/R machine structure is fixed on wooden base plate. Depth of storage cell and unit load is neglected. 9 cells are framed over rack frame considered as storage locations. Storage and retrieval machine consist of a horizontal moving carriage sliding over vertical moving platform. Horizontal and vertical platforms are made up of acrylic. Vertical moving platform is supported by aluminum framed pillars to which rack and pinion mechanism is fitted for linear motion. Picker arm is provided at horizontal moving carriage to pick the item from rack. Horizontal moving carriage and vertical moving platform and gripper arm are driven by dc gear through rack and pinion mechanism. Servo motor is provided to have

pick and place action of gripper arm Electronic circuitry is fixed over base plate at bottom.

Dimensions of AS/RS are given as:

1. Capacity per aisle = $3 \times 3 = 9$
2. Length of Unit load = 120mm
3. Height of Unit load = 100mm
4. Length of Pallet = 130mm
5. Height of Pallet = 30mm
6. Length of each storage cell = 150mm
7. Height of each storage = 150 mm
8. Total length of rack = 480mm
9. Total Height of Rack = 580mm

Automated storage and retrieval system under study is configured as:



Fig.1 AS/RS Prototype model

1. Single Aisle, rectangular, one sided pick face rack, is considered.
2. Single S/R machine is used.
3. Input-Output station is considered at location 1, lower right corner in the rack.
4. Only 2 dimensions length and height of unit load, pallet and storage rack are considered. Depth is neglected.
5. Each space contains single unit load only.
6. All storage locations as well as unit loads are identical in shape and size.
7. S/R machine operates on Single command cycle.
8. S/R machine has independent drives for vertical and horizontal travel movement.
9. The specification of the S/R machine such as maximum velocities in horizontal and vertical directions as well as the length and the height of the S/R machine are known.
10. Input-output station: Location 1 in the rack (Row1, Column1)
11. Velocity of horizontal platform: 2.6m/s
12. Velocity of vertical platform: 2.6m/s

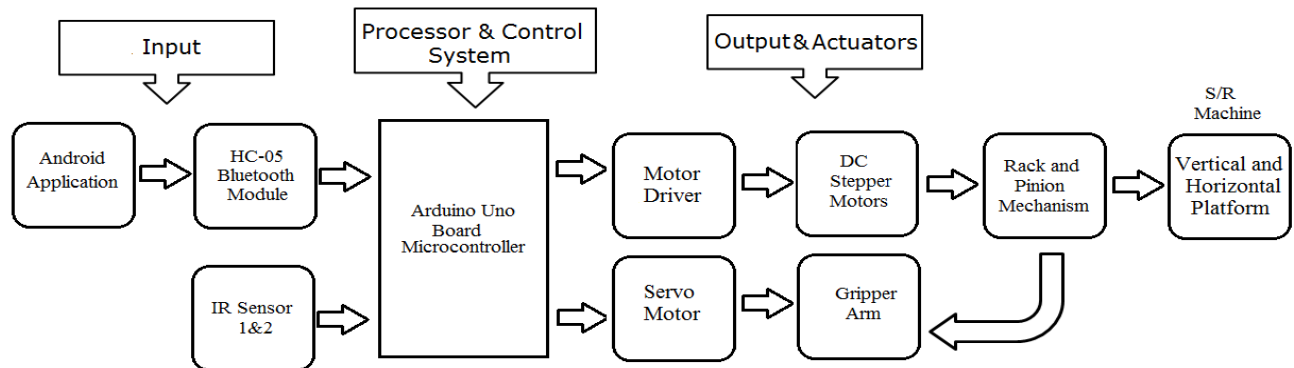

Fig. 2 System architecture

B. Mechatronic System of AS/RS

Basic product architecture expresses three stages of automated storage and retrieval system-input, processor and control system and output and actuator stage. The mechatronic system consists of combination of electrical and electronic devices along with a mechanical structure. Integration of this system involves successful interaction between input and output by means of suitable control system.

Input stage involves observation and measurement of parameter necessary to produce information signal which may be analog or digital. Physical entities such as temperature, distance, pressure, velocity is measured to produce digital output signal – a high or low (1 or 0). Android application system provides selection of parameters, such as physical location in the rack through Bluetooth interfacing to exchange data with the control system. This signal is analyzed and processed further by control system to generate necessary action signal for actuators.

Control system is an information processing unit consists of computer hardware and software system. This control system gathers various commands and action plans in the form of digital code and operate according to program code provided by user. Information signal produced at input stage is faded to the control system that analyzes this information and follows the preference provided by user in the form of logic, language or code. It will then produce necessary signal for the actuator. Hence, control system supervises

and conducts the inputs as well as outputs according to the program code.

Thus, Control system does real time information processing and decision-making to manage the input and outputs. Suitable Communication media is provided along with Control system to interface input-outputs with the control system which may convert signal to suitable form.

Output stage consists of actuators that convert digital signal into physical action. Actuator requires digital control signal in the form of energy, voltage or current, pneumatic, hydraulic or human pressure to work. Hence, actuators are of electrical, pneumatic or hydraulic type depending on source of signal. Two basic actions-linear and rotary are generated by actuators. Precision and response time are important while selecting actuator for operation. Feedback from actuator is given to the control system to operate actuator according to program code. So, the output is faded back to the controller to control the working cycle of mechatronic system.

Figure 3 shows the block diagram of automated storage and retrieval system. Input stages consist of Android application and Bluetooth communication system which is human-machine interface media whereas IR sensor is used to attend the correct position by detecting the color strips in conjunction with dc motor.

Arduino UNO microcontroller is provided to control inputs as well as actuators. It uses program code to conduct and synchronize the operation of AS/RS. It is connected through suitable communication media with input and output such as Bluetooth, electrical wired connections, etc. It admits the signal from Android application system and IR sensor and converts it to suitable control signal according to program decisions. This control signal is transferred to actuators whenever necessary according to program code.

Actuators are used to create actual motion of S/R machine. DC stepper motor, servo motors are used to produce linear translational motion of vertical and horizontal platforms and angular rotation of gripper jaws. Rack and pinion mechanism is used to convert rotary motion from DC stepper motor to linear motion of platforms and gripper arm.

TABLE I LIST OF COMPONENTS

| Component | Specification | Quantity |
|--|---|----------|
| Acorduino Uno Board | ATmega 328 Microcontroller Operating Voltage: 5V | 1 |
| HC-05 Bluetooth Module | 3.3V DC | 1 |
| IR Sensor | 3.6 to 5V DC | 2 |
| DC Gear Motor (Vertical and Horizontal Platform) | 12V DC, 60rpm | 3 |
| DC Gear Motor (Gripper Assembly) | 12V DC, 10rpm | 1 |
| DC Servo Motor (Gripper Arm) | 5V DC | 1 |
| LM-298 Driver | 5-35V DC | 3 |

IV. ANALYSIS OF AS/RS

Yavuz Bozer *et al.* [8] have proposed mathematical expression for expected travel run which is evaluated under various dwell point locations of S/R machine. Dwell point is the position where machine goes idle after completion of operation until next order of operation. As the throughput of the system is dependent on expected travel time, travel time calculation is fundamental step in design of AS/RS. Throughput of system can be improved by reducing travel time. Following assumptions are considered while calculating travel time:

1. Continuous pick face rack is considered.
2. S/ R machine operates on Single Command and Dual Command Cycle.
3. No intermediate stop allowed across the aisle.
4. Velocity of S/R machine remains constant during horizontal and vertical travel.
5. Random storage allocation provided so that each space has equal probability of getting selected.
6. Rack dimensions, Horizontal and vertical velocities of S/R machine, Position of Input-Output location and Dwell strategy must be known initially.
7. Pick up and Deposit time is irrespective of rack shape and velocities of S/R machine. So, Average pick up and deposit time is added at the last to the equation of Expected cycle time.
8. Under Dwell point strategy A, B, C, Dall operations considered are single command storage or retrieval, $\alpha = 1$.
9. Dwell point strategies considered for study are given as below:

TABLE II DWELL POINT STRATEGIES FOR VARIOUS LOCATIONS OF INPUT -OUTPUT STATION

| Strategy | Location of Input –Output Station | Operation | Single Command Cycle | Dual Command Cycle |
|----------|-----------------------------------|--------------------|--------------------------------|--------------------------------|
| A | At same end of aisle | Storage /Retrieval | Return to Input–Output Station | Return to Input–Output Station |
| B | At opposite ends of aisle | Storage | Return to Input Station | Return to Output |
| | | Retrieval | Return to Output Station | |
| C | At opposite ends of aisle | Storage | Remains at Storage Location | Return to Output |
| | | Retrieval | Return to Output Station | |
| D | At mid-point location | Storage /Retrieval | Return to Mid-point location | Return to Mid-point location |

Mathematical Expressions for various dwell point strategies: Strategy A: $T(SC) = T \cdot \left(\frac{b^2}{3} + 1\right) + 2 \cdot T_{PD}$
 Strategy B: $T(SC) = E(SC) + \frac{K}{4} + 2 \cdot T_{PD}$
 Strategy C: $T(SC) = \frac{3}{4} \cdot E(SC) + \frac{1}{4} \cdot E(TB) + 2 \cdot T_{PD}$
 Strategy D: $T(SC) = \frac{1}{2} \cdot E(SC) + 2 \cdot T_{PD}$

Where
 T (SC) – Total travel time for single command cycle.
 E(SC) – Expected time for single command cycle.

E(TB)- Expected time for travel between storage and retrieval locations.
 b- Shape factor = $\text{Min} \left(\frac{T_H}{T}, \frac{T_V}{T} \right)$
 T_{PD} - Load pick-up and deposit time.
 T_H – Time required traveling up to L.
 T_V – Time required travelling up to H.

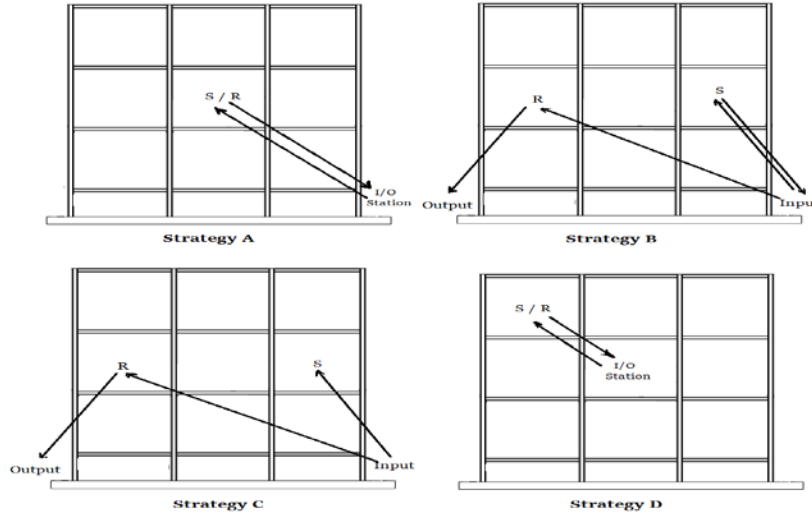

Fig.3 Dwell point strategies

A. Comparison of Expected Cycle Time for Various Dwell Point Strategies

TABLE III COMPARISON OF EXPECTED CYCLE TIME FOR SINGLE COMMAND CYCLE UNDER VARIOUS- DWELL POINT STRATEGIES

| Location | Row | Column | Dwell Point Strategies | | | |
|----------|-----|--------|------------------------|------------|------------|------------|
| | | | Strategy A | Strategy B | Strategy C | Strategy D |
| 1 | 1 | 1 | 26.00 | 53.87 | 26.00 | 26.00 |
| 2 | 1 | 2 | 38.31 | 66.18 | 36.26 | 32.15 |
| 3 | 1 | 3 | 50.62 | 78.49 | 46.51 | 38.31 |
| 4 | 2 | 1 | 38.31 | 66.18 | 36.26 | 32.15 |
| 5 | 2 | 2 | 42.41 | 70.28 | 39.74 | 34.21 |
| 6 | 2 | 3 | 52.67 | 80.54 | 48.28 | 39.33 |
| 7 | 3 | 1 | 50.62 | 78.49 | 46.51 | 38.31 |
| 8 | 3 | 2 | 52.67 | 80.54 | 48.28 | 39.33 |
| 9 | 3 | 3 | 58.82 | 86.69 | 53.49 | 42.41 |

Table 3 and Figure 5 shows Comparison of Expected Cycle time under various dwell point strategies for single and dual command cycles, respectively. Mathematical model for travel time analysis under various strategies of dwell point location has been studied to select best possible dwell point location for AS/RS operation. Selection of dwell point affects total travel run, so the best strategy minimizes travel

time along with operational cost. Figure shows that Strategy D outperforms over other strategies with the least travel time. But selection of strategy D adds up increase in cost as mid-point location requires additional delivery and take-away conveyors running half-way into the aisle, through a set of rack openings located at the mid-level on either side of the aisle.

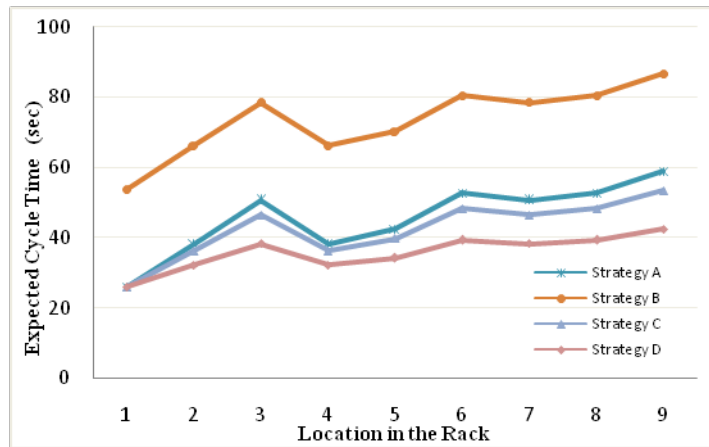

Fig.5 Expected cycle Time for Single Command Cycle under Various Dwell Point Strategies

Strategy C is another less time-consuming dwell point strategy after Strategy D. It involves storage operation ending at storage location which reduces travel distance by dwelling at storage location. Depending upon next operation S/R machine will move towards input or output location. But best control over operational system should be required as it involves sorting of storage and retrieval requests with the order picking priority. Separate input and output station demand separate setups at both ends of aisle acquiring side areas of aisle.

Strategy A demand only one input-output station with good control over entire operation as S/R machine returns to input-output station after completion of each operation. Travel time is slightly greater than strategy C, but it is justified with simplification of operational control, sorting of requests and order picking.

Strategy B is as same as strategy C except storage operation terminating at input station. Compared to remaining strategies, travel time is more as it adds up travel distance from storage location to input station after every storage operation. Hence, from the study it can be concluded that Strategy A and C are preferable while having AS/RS operation, but Strategy A is simpler and easier to install and control the entire operation at an initial level of travel runs.

Once having a good control over transaction requests and operation it is easy to adopt strategy C with small investment in a setup and control system.

B. Effect of Various Dwell Point Strategies on Throughput of System

System throughput is defined as rate of transactions per hour performed by automated storage and retrieval system. The transactions include number of storage or retrieval requests completed.

Let consider,

If Average cycle time for storage or retrieval operation = 26 Sec

∴ Number of storage or retrieval operations completed per hour

$$= \frac{60 \times 60}{26} = 138.46 \text{ cycles}$$

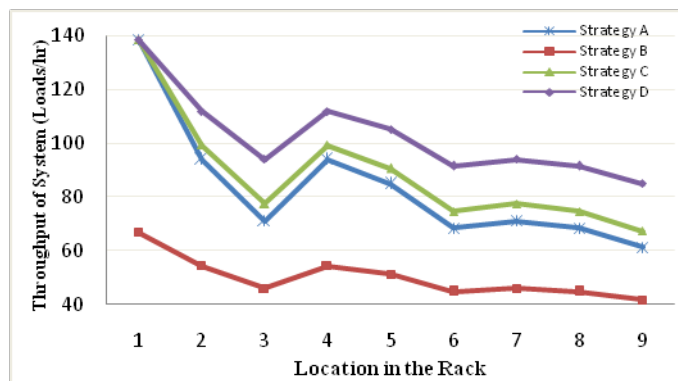

Fig.6 Throughput of System under Various Dwell Point Strategies

System throughput = Number of Storage / retrieval operations completed per hour
 \therefore System throughput = 138 cycles/hour or loads/hour

Figure 6 shows through put of system under various dwell point strategies. Throughput of system decreases with increase in expected cycle time. Cycle time considered here is theoretical expected cycle time. Strategy D is having higher throughput than other dwell point strategies, but it demands section of mid- point location for dwell point and additional material handling system to load-unload unit load which becomes costlier. Selection of strategy A or C seems same as throughput is nearly same. As strategy A is simple and no special control set up requirements as compared to C, Strategy A is cost effective and more suitable as compared to Strategy C and B.

C. Influence of Shape Function (b) On Expected Cycle Time and Throughput of System

TABLE IV INFLUENCE OF SHAPE FUNCTION ON EXPECTED CYCLE TIME AND THROUGHPUT OF SYSTEM

| Shape Function (b) | 0.00 | 0.50 | 0.67 | 0.75 | 1.00 |
|---------------------------------|-------|-------|--------|-------|-------|
| Expected Cycle Time (sec) | 84.82 | 87.79 | 109.07 | 91.40 | 74.15 |
| Throughput of System (Loads/hr) | 42.44 | 41.00 | 33.01 | 39.39 | 48.55 |

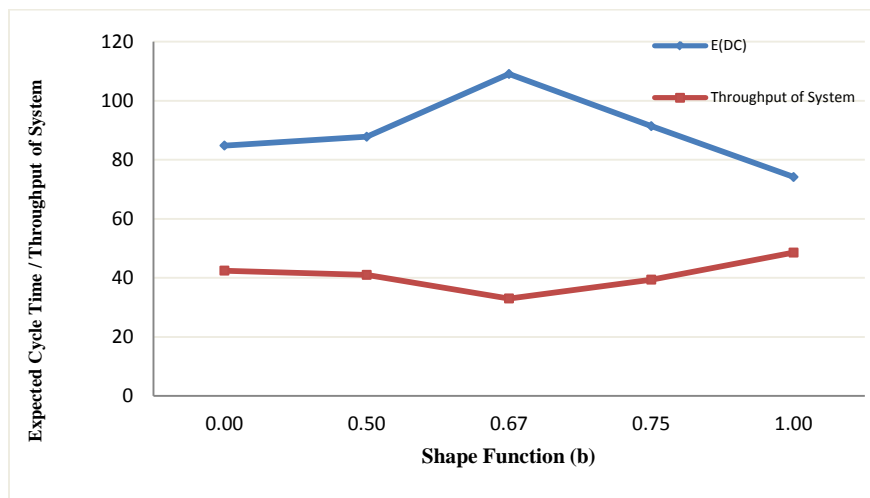

Fig.7 Influence of shape function on expected cycle time and throughput of system

Table 4 and figure 7 shows influence of shape function on expected cycle time and throughput of the system. According to figure expected cycle time increases with shape function until $b=0.67$, after achieving maximum expected cycle time at $b=0.67$ it attains gradual decrease up to $b=1$. Similarly, for Throughput of the system decreases as expected cycle time and shape function increases, at $b=0.67$ minimum throughput is attained and starts increasing slowly toward $b = 1$. Hence, optimum throughput is possible at $b=1$ for given configuration of system and strategy A.

V. CONCLUSION

Mathematical expected travel time expressions are verified on experimental model to study effect of dwell point strategy on expected travel time and throughput of system. Though strategy D outperforms, it is costlier than other dwell point strategies. Hence, Strategy A and C are suitable while having newly installed AS/RS. Arduino UNO prototyping platform is low cost solution to programmable control system. Wireless remote operated manual control is possible through Bluetooth operated android application.

Hence, AS/RS prototyping adopts multidisciplinary knowledge gain in technical skills.

REFERENCES

- [1] M. R. Vasili, S.H. Tang, S.M. Homayouni, and N. Ismail, "Comparison of Different Dwell Point Strategies for Split Platform Automated Storage and Retrieval System", *International Journal of Engineering and Technology*, Vol.3, No.1, pp. 91-106, 2006.
- [2] Mohammadreza Vasili, Mehadi Vasili, Reza Raminfar, Pooria Matoorian, "A Closed Form Model for Travel Time of Split Platform Automated Storage and Retrieval System Equipped with Two Input/ Output Stations", *9th International Conference of Modelling, Optimization and Simulation*, June 06-08, 2012.
- [3] Mohammadreza Vasili, Seyed Mahdi Homayouni, "Load Shuffling and Travel Time Analysis of Miniloat Automated Storage and Retrieval System with an Open Rack Structure", *Proceedings of the 41st International Conference on Computers & Industrial Engineering*, pp.900-905, January 2011.
- [4] Po-Hsun Kuo, Ananth Krishnamurthy, Charles J. Malmborg, "Models for Unit Load Storage and Retrieval Systems Using Autonomous Vehicle Technology and Resource Conserving Storage and Dwell Point Strategies", *Applied Mathematical Modeling*, Vol.31, 2007, pp. 2332-2346.
- [5] Tone Lerher, Matjaz Sram, Janez Kramberger, Iztok Potrc, Matej Borovinsek, Blaz Zmazek, "Analytical Travel Time Models for Multi Aisle Automated Storage and Retrieval Systems", *International*

- Journal Advanced Manufacturing Technology*, Vol.30, pp.340–356, 2006.
- [6] Yaghoub Khojasteh, Ghamari, Shouyang Wang, “A Genetic Algorithm for Order Picking in Automated Storage and Retrieval Systems with Multiple Stock Locations”, *IEMS* Vol. 4, No. 2, pp. 136-144, December 2005.
- [7] Ya-Hong Hu, Shell Ying Huang, Chuanyu Chen, Wen-Jing Hsu, Ah Cheong Toh, Chee Kit Loh, Tiancheng Song, “Travel Time Analysis of A New Automated Storage and Retrieval System”, *Computers & Operations Research*, Vol.32, pp. 1515–1544, 2005.
- [8] Yavuz A. Bozer, John A. White, “Travel-Time Models for Automated Storage/ Retrieval Systems”, *IIE Transactions*, Vol. 16, No.4, pp.329-338, 1984.
- [9] Zaki Sari, Adel M. Hamzaoui, “Optimization of a Single Machine Flow Rack AS/RS for Minimum Expected Travel Time”, 11th IFAC Workshop on Intelligent Manufacturing Systems, *The International Federation of Automatic Control*, May 22-24, 2013.