

# Design, Analysis and Fabrication of Hydraulic Scrap Baling Machine

S. V. Kumbhar<sup>1</sup>, M. A. Jadhav<sup>2</sup>, Avesahemad Husainy<sup>3</sup>, S. G. Bardiya<sup>4</sup>,  
Omkar B. Patil<sup>5</sup> and Shubham K. Mali<sup>6</sup>

<sup>1,2,3&4</sup> Assistant Professor, <sup>5&6</sup> Student,

Department of Mechanical Engineering, S.I.T. College of Engineering, Maharashtra, India  
E-Mail: [sujit.kumbhar64@sitcoe.org.in](mailto:sujit.kumbhar64@sitcoe.org.in), [mandarjadhav@sitcoe.org.in](mailto:mandarjadhav@sitcoe.org.in), [avesahemad@gmail.com](mailto:avesahemad@gmail.com)

**Abstract** - There are several industrial production processes that involve mechanical machining of cast parts by various operations such as turning, milling, and drilling. Metal Chips, especially of aluminum, mild steel and cold-rolled carbon steel, etc. The collection, storage, and transportation of metal chips are an important aspect in the process of recycling. This project focuses on the compaction and creation of metal chips bales for ease of storage as well as handling and transportation of metal chips. Efforts have been taken to ensure an efficient waste management system in shop floors, with minimum use of space and energy when it comes to disposing of metal chips formed during machining processes. The large space required to store the chips as loose chips have a large surface area. The scope of the project is limited to the design, analysis, and fabrication of scrap baling machine. A Baling press machine is a machine in which a loose scrap is converted into the form of 8-12 kg bundle. In this machine, we adopt a square bundle rather than circular shape and square bales acquire less space as compared to the round bales.

**Keywords:** Hydraulics, Scrap Baling, Steel Scrap, Pascal's Law

## I. INTRODUCTION

Nowadays, the development of economy and society is facing the exhaustion of primary resources and the crisis of traditional energy. The green economy and circular economy has become a new trend of global sustainable development [1]. As a kind of important energy-saving and emission reduction and renewable resources, scrap iron and steel have received great attention [2-4]. It has a very important practical significance that the scrap iron and steel resources had been effectively exploited and used to save resources and protect the environment.

At present, the scrap ratio in the iron and steel industry of developed countries had increased to more than 40-50% [3, 4]. In China, by contrast, it only maintained at a very low level of 14-23%. So the utilization of steel scrap had become a long-term strategic policy for the reform and development of the iron and steel industry in China [3, 4]. The scientific classification processing of steel scrap and the scrap concentrate steelmaking which has yet to be resolved had become an important issue in the metallurgical industry.

In recent years, although the sort and measure of scrap steel processing equipment are increasing, the requirement of social development has not been satisfied in China. The backward equipment in the iron and steel scrap processing had stood in the way of the iron and steel production

enterprise stepping forward. It is a vital reason also that the increase in scrap ratio was restricted in the iron and steel industry [4]. Meanwhile, with the development of economic modernization, kinds of scrap steel became more and more, such as large structures, containers, waste planking and so on, which is difficult to process. So larger processing capacity and range of working limits were proposed to be used in the scrap processing equipment [4]. In a developed country, oil-hydraulic scrap baling press is developing towards large-scale which has reached more than 1500 tons for processing capacity. Therefore, it is one of the effective ways that sustainable development in the iron and steel industry will be promoted by the development of large-scale, automated, high-efficiency scrap processing technology and equipment.

All in all, both processing method of steel scrap and the mechanical equipment for processing steel scrap is not as advanced as that in developed countries [3]. The steel scrap in China is still mainly processed by manpower and simple mechanical device. Moreover, additional encouragement for investment in scrap steel industry would be beneficial [3]. The needs for heavy oil-hydraulic scrap baling press had existed in the domestic market, combining with the real situation in China.

## II. THEORY

Mechanical manufacturing processes are major of two types one is additive manufacturing and another is subtractive manufacturing. Subtractive manufacturing is the most widely used manufacturing process. In this method, the material is removed from a block or bar provided to get the desired shape and size with controlling its dimensions. this method consists of different processes like turning, facing, boring, milling, etc. these processes are carried out on different types of pieces of machinery like lathe machine, CNC machine, VMC machine, milling machine, drilling machine, etc. these all machines removes material into the chip forms. The chips formed in different processes having different nature in terms of shape size and length etc. the scrap chips is the major waste product produced in every mechanical manufacturing industry

A baling machine is a device used to compress materials into a bale form which is easy for storage, transport, and

handling. Hydraulic scrap baling presses are machinery that finds usage to compress different types of scraps into bale forms using the hydraulic system. These presses are used in different ways to compress light, thin as well as soft materials. These Balers are also used in material recycling facilities. The bale can be formed into square bales. Further, as the density of bales is high, these are also convenient to store, transport and used in foundries. Machining companies sell their chips as scrap material, while foundries use it as a bulk material in their own melting units or sell it to scrap dealers. Loose chips have, however, many disadvantages. Hence compared with large part scrap (turning scrap, casting scrap, etc.), chips get considerably lower market prices. The bulk weight of chips of the same volume of is eight to ten times higher than (i.e.12.5%) that of solid scrap. With the increasing trend of the scrap generation procedure, it has become a necessity to implement a refined technology to perform the entire method efficiently. In addition, there turns of taking loose scrap and collecting in a specific area then taking off weight is reduced by this machine and also a reduction in transportation cost that forms another vital favorable aspect of the scrap balers. It occupies minimum space in the factory that enables the industries to maintain the system operationally. To overcome these all the problems and benefit we construct a hydraulic scrap baling machine.

### III. CONSTRUCTION AND WORKING

#### A. Working Principle

A simple hydraulic system consists of hydraulic fluid, pistons or rams, cylinders, oil reservoir, a complete working mechanism, and safety devices. Transmission of force is carried by the hydraulic fluid, in a confined medium. Modern developments in hydraulics have involved many fields in engineering and transportation. These systems transfer high forces rapidly and accurately even in small pipes of light weight, small size, any shape, and over a long distance.

Pascal's law:- Pascal's Law, framed by Blaise Pascal, states that "Pressure applied to any part of a confined fluid transmits to every other part with no loss. The pressure acts with equal force on all equal areas of the confining walls and perpendicular to the walls." This is the basic principle for any hydraulic system.

A hydraulic scrap baling machine is used to compress small chips (such as boar, blanks, and turning) into compact size bundle that is easy to handle, transport, and store.

#### B. Construction

The hydraulic scrap baling machine consists of fabricated structure hydraulic cylinders, opening doors, and Hydraulic power pack with hydraulic valves, etc. The fabricated structure includes cavity base plate two side wall plates which are supported with rigid support of the C-channel

structure. Also, consist of an upper cylinder supporting structure which is welded to the bottom and side walls of the machine the fabricated structure also consists of upper compressing which is hinged between side walls. The machine is working with two hydraulic cylinders one is at the bottom in the horizontal direction and other is at the top in an inclined position which is mounted with intermediate trunnion mounting to cylinder supporting structure. There are two doors. One closes from the front due to engagement in the slot provided on the side door. The hydraulic power pack consists of the 300-liter oil tank, pressure gauge, hydraulic valves, etc. The two side walls one bottom plates creates a cavity for pressing scrap

#### C. Working

The machine works on the simple hydraulic Pascal's law. The total compressing process is of two steps one is with upper hydraulic cylinder and other is with a lower horizontal cylinder. The operation starts with the pouring of turning scrap into the cavity provided in the machine after that with the lever operated valve the upper cylinder is actuated which pushes the upper compressing plate into the cavity till stoppers provided to the upper plate rests on the cavity side wall. After that second horizontal lower cylinder gets actuated with the lever operated valve it compresses the material inside the cavity to its limit then the lever moves to cutoff position. The door is opened manually and again lower cylinder is actuated with the lever valve which pushes the ball to the out of the machine.



Fig. 1 Hydraulic Scrap baling Machine

### IV. DESIGN OF MACHINE

#### A. Amount of Scrap Material Required

Required bale size = 203.2 mm × 203.2 mm × 101.6 mm

Density of loose scrap 150 kg/m<sup>3</sup>

After compression density increases to 12 times of loose scrap

Then density of compressed material = 1800 kg / m<sup>3</sup>

Mass of material required = volume after compression × density of compressed bale

$$= 0.00419 \text{ m}^3 \times 1800 \text{ kg} / \text{m}^3$$

$$= 7.54 \text{ kg}$$

### B. Determination of Size of Cavity

Cavity volume  $\times$  Density = mass of material

$$L \times B \times H \times 150 \text{ kg/m}^3 = 7.54 \text{ kg}$$

$$L \times 0.2032 \text{ m} \times 0.3048 \times 150 \text{ kg/m}^3 = 7.54 \text{ kg}$$

$$L = 0.811 \text{ m}$$

We have considered  $L = 0.850 \text{ m}$

$$= 850 \text{ mm}$$

### C. Design Specification for Cylinders

#### For Horizontal Cylinder

1. Tonnage: 50 ton

2. Pressure: 200 bar

#### Cylinder Diameter

$$\text{Area} = \text{force/pressure}$$

$$= 500000 / (200 \times 10^5)$$

$$= 0.025 \text{ m}^2$$

$$D = \sqrt{4 \times 0.025 \pi}$$

$$= 0.1784 \text{ m}$$

$$= 178 \text{ mm}$$

From Standard catalogue we selected

Piston Diameter= 180 mm

Piston Bore Diameter = 100mm

#### For Upper Cylinder

1. Tonnage: 37 ton

2. Pressure: 200 bar

#### Cylinder Bore Diameter

$$\text{Area} = \text{force/pressure}$$

$$= 370000 / (200 \times 10^5)$$

$$= 0.0185 \text{ m}^2$$

$$D = \sqrt{4 \times 0.0185 \pi}$$

$$= 0.1534 \text{ m}$$

$$= 153 \text{ mm}$$

From Standard catalogue we selected

Piston Diameter= 150 mm

Piston Bore Diameter = 85 mm

Assuming oil flow rate 27 LPM

$$1 \text{ LPM} = 0.26 \text{ GPM}$$

$$1 \text{ bar} = 14.5 \text{ psi}$$

$$\text{HP} = \text{GPM} \times \text{PSI} / 1714$$

$$= 7.13 \times 2900.75 / 1714$$

$$= 12.06 \text{ HP}$$

$$= 9 \text{ kW}$$

#### E. For Horizontal Cylinder

For Bore side,

$$\text{Volume} = \pi \times r^2 \times L$$

$$= \pi \times 0.092 \times 0.850$$

$$= 0.02162 \text{ m}^3$$

$$= 21.62 \text{ lit.}$$

Time for horizontal cylinder = Volume / Oil flow rate

$$= 21.62 / 27$$

$$= 48.27 \text{ sec}$$

Velocity = stroke length / time

$$= 0.850 / 48.27$$

$$= 0.01760 \text{ m/sec}$$

For Rod side,

$$\text{Volume} = \text{vol. of bore side} - \pi \times r^2 \times L$$

$$= 0.02162 - \pi \times 0.052 \times 0.850 = 0.01492 \text{ m}^3$$

$$= 14.92 \text{ lit.}$$

Time = Volume / Oil flow rate

$$= 14.92 / 27$$

$$= 33.23 \text{ sec}$$

Velocity = stroke length / time

$$= 0.850 / 33.23$$

$$= 0.0255 \text{ m / sec}$$

#### For Upper Cylinder

For Bore side,

$$\text{Volume} = \pi \times r^2 \times L$$

$$= \pi \times 0.0752 \times 0.48152$$

$$= 0.0085 \text{ m}^3$$

$$= 8.50 \text{ lit.}$$

Time = Volume / oil flow rate

$$= 8.50 / 27$$

$$= 18.90 \text{ sec}$$

Velocity = Stroke length / time

$$= 0.48152 / 18.90$$

$$= 0.02546 \text{ m / sec}$$

For Rod side,

$$\text{Volume} = \text{vol. of bore side} - \pi \times r^2 \times L$$

$$= 0.0085 - \pi \times 0.04252 \times 0.48152$$

$$= 0.0057 \text{ m}^3$$

$$= 5.75 \text{ lit.}$$

Time = Volume / oil flow rate

$$= 5.76 / 27$$

$$= 12.8 \text{ sec}$$

Velocity = stroke length / time

$$= 0.48152 / 12.8 = 0.03761 \text{ m / sec}$$

### D. Calculation for Total Cycle Time

Total cycle time = time for loading of material + time for forward stroke of upper cylinder + time for forward stroke of lower cylinder + Time for door opening + time for return stroke of upper cylinder + Time for return stroke of lower cylinder

$$= 45 \text{ sec} + 18.90 \text{ sec} + 48.27 \text{ sec} + 25 \text{ sec} + 12.8 \text{ sec} + 33.23 \text{ sec}$$

$$= 183.2 \text{ sec} = 3 \text{ min } 3 \text{ sec}$$

## V. THEORETICAL STRESSES ON DIFFERENT MACHINE COMPONENT

### A. Theoretical Stress on Bottom Plate

$$\begin{aligned} \text{Total area of base plate} &= (500 + 102.5 \times 4) \times 243.2 + (450 \times 343.2) \\ &= 37575.2 \text{ mm}^2 \\ \text{Force exerted by upper cylinder} &= 36 \text{ ton} = 353160 \text{ N} \\ \text{Stress on bottom plate} &= 353160/37575.2 \\ &= 9.398 \text{ N/mm}^2 \end{aligned}$$

### B. Theoretical Stress on the Front Door

$$\begin{aligned} \text{Total area of front door} &= (2 \times 37.5 + 334.49) \times (269.8 + 2 \times 37.5) \\ &= 3635.65 \text{ mm}^2 \\ \text{Force exerted by bottom cylinder} &= 50 \text{ ton} = 490500 \text{ N} \\ \text{Stress} &= 490500/3635.65 \\ &= 134.91 \text{ N/mm}^2 \end{aligned}$$

## VI. HYDRAULIC OIL SELECTION

High performance hydraulic oil with optimal anti-wear properties (AW-Additives) and high load capacity of the lubrication film. Its excellent oxidation resistance delivers good performance at higher temperatures and extended operating intervals. Antioxidants and corrosion-inhibitors, high pressure absorption, good ageing and temperature resistance, no foam absorbance, good emulsification.

Table I Hydraulic Oil 68 Specification

Item	Method	Typical
ISO Viscosity Grade	ISO 3448	46
Density@15°C,kg/L	ASTM D4052	0.884
Kinematic viscosity@100°C	ASTM D7042	10.5-11.3
Kinematic viscosity@40°C	ASTM D7042	60-65
Viscosity index	ASTM D2270	>160
Flash point, °C	ASTM D92	251
Pour point, °C	ASTM D97	-39

### A. Components Required

#### 1. Hydraulic Cylinder

Hydraulic cylinders get their power from pressurized hydraulic fluid, which is typically oil. The hydraulic cylinder consists of a cylinder barrel, in which a piston connected to a piston rod moves back and forth. The barrel is closed on one end by the cylinder bottom (also called the cap) and the other end by the cylinder head where the piston rod comes out of the cylinder. The piston has sliding rings and seals. The piston divides the inside of the cylinder into two chambers, the bottom chamber and the piston rod side chamber (rod end) A hydraulic cylinder is the actuator or "motor" side of this system. The "generator" side of the

hydraulic system is the hydraulic pump which delivers a fixed or regulated flow of oil to the hydraulic cylinder, to move the piston. The piston pushes the oil in the other chamber back to the reservoir. If we assume that the oil enters from cap end, during extension stroke, and the oil pressure in the rod end / head end is approximately zero, the force F on the piston rod equals the pressure P in the cylinder times the piston area A. The specifications of hydraulic cylinders used for hydraulic scrap baling machine is as follows

Table II Hydraulic Cylinder Specifications

Details	Bore Dia	Rod Dia	Stroke Length
Upper cylinder	150mm	85mm	481.52mm
Lower cylinder	180mm	100mm	850.00mm

#### 2. Hydraulic Power Pack

Hydraulic power packs are stand-alone devices, as opposed to a built-in power supply for hydraulic machinery. Some power packs are large, stationary units and others are more portable. They have a hydraulic reservoir, which houses the fluid, regulators that allow users to control the amount of pressure the power pack delivers to a valve, pressure supply lines and relief lines, a pump and a motor to power the pump. Function Hydraulic power packs typically offer a choice of valve connections, allowing users to connect them to a control valve or valves to power a variety of machines. The power pack supplies hydraulic power through a control valve to run another machine.

#### 3. Controls

a. *Pressure Control Valves:* These limit or control the hydraulic pressure within the hydraulic system

b. *Directional Control Hydraulic Valves:* Manual, electrical, pneumatic or hydraulic operated valves direct the oil flow around the system to operate actuators, motors or other functions. Instrumentation, Oil level and temperature protection switch, Pressure switches and filter clogging switches etc.

4. *Pressure Gauge:* The hydraulic system is designed to work in a set pressure range so the gauge must be rated for that range. Hydraulic pressure gauges are available to measure up to 10,000 psi, although maximum hydraulic pressure is typically in the 3,000 to 5,000 psi range.

Hydraulic gauges are often installed at or near the pump's pressure port for indication of system pressure, but can be installed anywhere on the machine where pressure needs to be monitored especially if sub-circuits operate at a pressure rate different from pump pressure, such as after a reducing valve.

5. Pressure Control Valve

Pressure-control valves are found in virtually every hydraulic system, and they assist in a variety of functions, from keeping system pressures safely below a desired upper limit to maintaining a set pressure in part of a circuit

6. Pressure Relief Valve

A relief valve or pressure relief valve (PRV) is a type of safety valve used to control or limit the pressure in a system; pressure might otherwise build up and create a process upset, instrument or equipment failure, or fire. The pressure is relieved by allowing the pressurized fluid to flow from an auxiliary passage out of the system. The relief valve is designed or set to open at a predetermined set pressure to protect pressure vessels and other equipment from being subjected to pressures that exceed their design limits.

Table III Material Selection

Mechanical properties	Metric	Imperial
Tensile Strength	400-550 Mpa	58000-79800 psi
Tensile Strength Yield	250 Mpa	36300 psi
Elongation at brake (in 200 mm)	20 %	20 %
Elongation at brake (in 50 mm)	23 %	23 %
Modulus of elasticity	200 Gpa	29000 ksi
Bulk modulus	140 Gpa	20300 ksi
Poisons ratio	0.26	0.26
Shear modulus	89.3 Gpa	11500 ksi

We have selected the material for the Baling press machine is Mild Steel because it have very good mechanical properties that we have needed while making the Baling press. Mild Steel consists of following mechanical properties-

1. Ductility
2. Durability
3. Corrosion Resistance
4. Toughness
5. Hardness

VII. AUTODESK FUSION 360 SOFTWARE 3D DRAWING

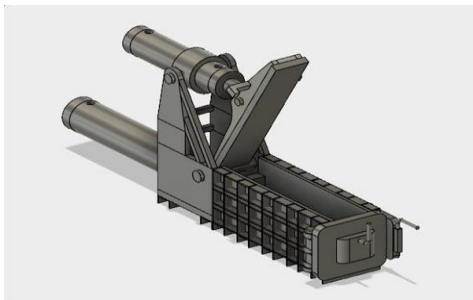

Fig. 2 Isometric View

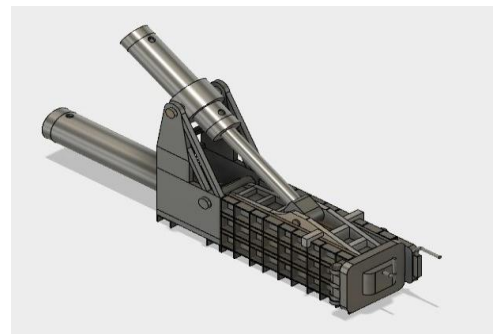

Fig. 3 Isometric View

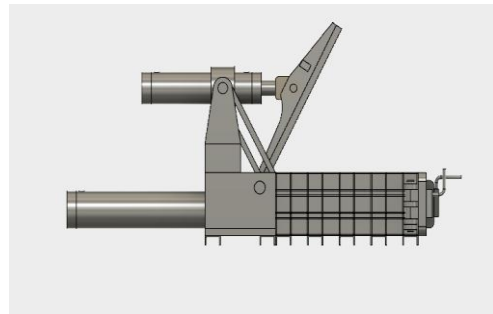

Fig. 4 Side View

VIII. MAIN MACHINE COMPONENT

A. Hydraulic Cylinders

1. Bottom cylinder
2. Upper cylinder

B. Fabricated structure

1. Base plate
2. Side walls
3. Upper pressing plate
4. Upper cylinder supporting structure

C. Hydraulic power pack

1. Hydraulic oil
2. Hydraulic valve, pump and motor and hoses

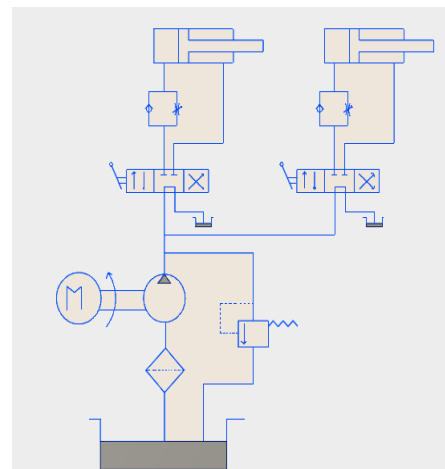

Fig. 5 Hydraulic circuit

**IX. STATIC STRESS ANALYSIS ON ANSYS SOFTWARE**

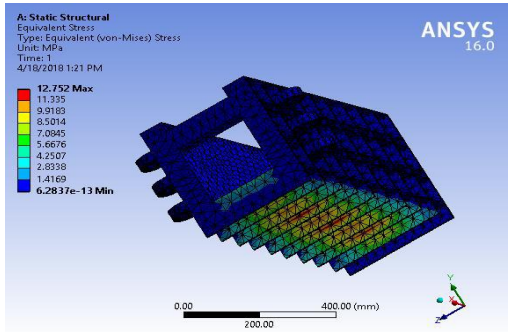

Fig. 6 Equivalent stress distribution of base plate

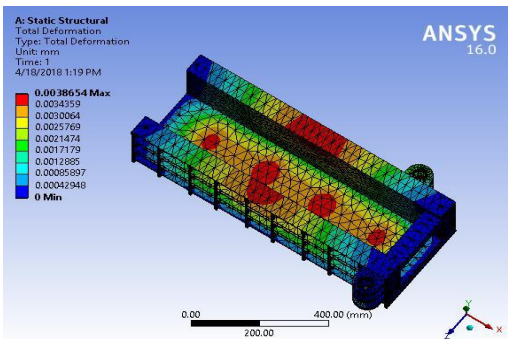

Fig. 7 Total deformation of base plate

TABLE IV BOUNDARY CONDITIONS

Object Name	Fixed Support	Force 1	Force 2	Force 3
State		Fully Defined		
Scope				
Scoping Method		Geometry Selection		
Geometry	15 Faces	Bottom plate	Right and left side wall	
Definition				
Type	Fixed Support	Force		
Suppressed		No		
Define By		Vector		
Magnitude	3.5e+005 N		1.e+005 N	
Direction		Defined		

**A. Analysis of Front Door**

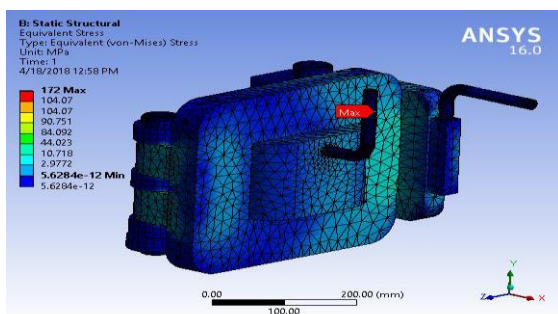

Fig. 8 Equivalent stress distribution of front door

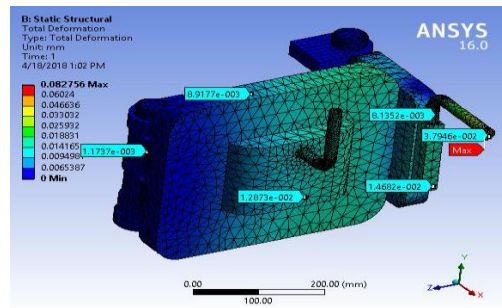

Fig. 9 Total deformation of front door

TABLE V BOUNDARY CONDITIONS

Object Name	Fixed Support	Force1
State		Fully Defined
Scope		
Scoping Method		Geometry Selection
Geometry	1 Face	Front door
Definition		
Type	Fixed Support	Force
Suppressed		No
Define By		Vector
Magnitude	5e+005 N	
Direction		Defined

TABLE VI ANALYSIS RESULTS

S. No.	Component	Theoretical stress (Mpa)	Maximum stress in analysis (Mpa)	Maximum deformation (mm)
1	Bottom plate	9.398	12.72	0.0038654
2	Front door	134.91	172	0.082756

The theoretical stress values and maximum stress developed in ANSYS simulation are nearly equal. The total deformation and strain in both the components is very negligible from these results the design is safe.

**X. CONCLUSION AND PERSPECTIVES**

1. The cost of transportation, storage, handling is reduced due to the bales requires minimum storage area in transportation containers and in the storage rooms.
2. It reduces the possibility of injury to workers and improves safety of workers.
3. After completion of project we got best optimized reduced weight hydraulic scrap baling machine. The cost of the machine is low compared to market product. There is about 50% reduction in the cost. Due to implementation of this technique it reduces the human efforts. This machine is also used for compressing the waste utensils.



4. The cost of the machine is low compared to market product; there is 50% reduction in the cost.
5. The transportation cost per sack without compressing the utensils is Rs 24/sack and if we compressed using this machine the cost comes up to Rs 8/sack.

#### A. Percentage cost reduction

$$\begin{aligned} & \text{(Market price - manufacturing cost of designed} \\ & \text{machine)/market price} \times 100 = [(450000-231500)/45000] \\ & \times 100 \\ & = 48.55 \% \end{aligned}$$

So, the percentage in cost reduction is found to be 48.55%

### REFERENCES

- [1] Roman Schmaltz, Robert J. Wolf, and Enrich E. Salzmann, "Baler Machine and Method of Baling", U.S. Patent 5, 201, 266, Apr. 13, 1993.
- [2] James K. Robbins, "Method for compacting material using a horizontal baler with movable bottom support ejector", U.S. Patent 5,247,880, Sep. 28, 1993.
- [3] J. N. Ding, Y. G. Meng, and S. Z. Wen., "Specimen size effect on mechanical properties of polysilicon micro cantilever beams by deflection using nanoindentation", *Material science and Engineering B.*, Vol. 83, No. 1-3, pp. 42-47, 21 June 2001.
- [4] M. P. Bendsoe, E. Lund, N. Olhoff, and O. Sigmund, "Topology optimization-broadening the areas of application", *Control and Cybernetics*, Vol. 34, No. 1, pp. 7-35, 2005.
- [5] Yu Wei, and X. W. Wang , "Computer simulation and experimental study of machining deflection due to original residual stress of aerospace thin-walled parts", *The international journal of advanced manufacturing technology*, Vol. 33, No. 3-4, pp. 260-265, 2007.
- [6] Waqas Saleem, Fan Yuqing, and Wang Yunqiao , "Application of Topology Optimization and Manufacturing Simulations -A new trend in design of Aircraft components", *Proceedings of the International MultiConference of Engineers and Computer Scientists*, Vol. 2, IMECS 2008, pp. 19-21 March, 2008.
- [7] Dr. H. K. Amarnath, Vaibhav Deshpande, Abhishek Kulkarni, Mahesh Patil, Omkar Ravan, and Sagar Chougule, "Design and Fabrication of Paper Bailing Machine", *International Research Journal of Engineering and Technology (IRJET)*, Vol. 4, No. 6, June -2017.
- [8] S. Lakshmi Priya, S. Narasinga Rao, S. Shyam Vignesh, A. Murugan, and A. Iogesh, "Low Cost Plastic Balers", *International Research Journal in Advanced Engineering and Technology (IRJAET)*, Vol. 4, No. 2, pp. 2863-2872, 2018.